Table of Contents

NG Engine Technology

Subject	Page
New Generation Engine Technology	5
Turbocharging	6
Turbocharging Terminology	6
Basic Principles of Turbocharging	7
Bi-turbocharging	10
Air Ducting Overview	12
Boost-pressure Control (Wastegate)	14
Blow-off Control (Diverter Valves)	15
Charge-air Cooling	18
Direct Charge-air Cooling	18
Indirect Charge Air Cooling	18
Twin Scroll Turbocharger	20
Function of the Twin Scroll Turbocharger	22
Diverter valve	22
Tuned Pulsed Exhaust Manifold	23
Load Control	24
Controlled Variables	25
Service Information	26
Limp-home Mode	26
Direct Injection	28
Direct Injection Principles	29
Mixture Formation	30
High Precision Injection	32
HPI Function	33
High Pressure Pump Function and Design	35
Pressure Generation in High-pressure Pump	36
Limp-home Mode	37
Fuel System Safety	38
Piezo Fuel Injectors	39
Injector Design and Function	40
Injection Strategy	42

Subject	Page
Piezo Element43
Injector Adjustment43
Injector Control and Adaptation44
Injector Adaptation44
Optimization45
HDE Fuel Injection46
VALVETRONIC III47
Phasing47
Masking47
Combustion Chamber Geometry48
VALVETRONIC Servomotor50
Function50

**BLANK
PAGE**

NG Engine Technology

Model: All from 2007

Production: All

OBJECTIVES

After completion of this module you will be able to:

- Understand the technology used on BMW turbo engines
- Understand basic turbocharging principles
- Describe the benefits of twin Scroll Turbochargers
- Understand the basics of second generation of direct injection (HPI)
- Describe the benefits of HDE solenoid type direct injection
- Understand the main differences between VALVETRONIC II and VALVETRONIC III

New Generation Engine Technology

In 2005, the first of the new generation 6-cylinder engines was introduced as the N52. The engine featured such innovations as a composite magnesium/aluminum engine block, electric coolant pump and VALVETRONIC for the first time on a 6-cylinder.

To further increase the power and efficiency of this design, three new engines were introduced for the 2007 model year. These engines are the N52 K, the N51 SULEV II and the N54.

The N52K (N52KP) engine is the naturally aspirated version of the new 6-cylinder engines. The "K" designation indicates that there are various efficiency and cost optimization measures. This engine can also be referred to as the "KP" engine.

The measures include new optimized components such as the consolidation of various items such as the crankcase ventilation system into the cylinder head cover.

The N51 engine is introduced to comply with SULEV II requirements. The N51 features much of the same measures and technology as the previous SULEV engine, the M56.



The N54 engine is the first turbocharged powerplant in the US market. In addition to turbocharging, the N54 features second generation direct injection and double VANOS.

Based on the N54, the N63 twin turbo V8 was launched with the introduction of the E71 xDrive50i in 2008. It features double VANOS, DI and two turbochargers.

In 9/2009 the successor of N73, the N74 V12 was introduced with the launch of the F01/F02 760i/760Li. This engine largely based on N73 and N63 technology.

The N55 engine is the direct successor to the N54 engine and was introduced to the US market with the in the launched of the F07 535i Gran Turismo in the Spring of 2010. Technical updates and modifications make it possible to use only one exhaust turbocharger. The technical data have remained virtually the same - with reduced costs and improved quality.

The N55 combines for the first time VALVETRONIC III with double VANOS, direct injection and turbocharging and is referred to as TVDI.

Turbocharging

As far as gasoline engines are concerned, turbocharging has not been in widespread use at BMW. As a matter of fact, the last turbocharged BMW production vehicle was the E23 (745) which was not officially imported into the US. The previous “turbo” model before that was the legendary 2002 tii turbo in the early 1970’s. This 2002 tii turbo was also not officially imported into the US.



Until now, BMW has built a reputation for building high performance engines which are naturally aspirated. Much research has gone into the development of an efficient engine design which meets not only the expectations of the customer, but complies with all of the current emissions legislation.

Currently, the global focus has been centered around the use of alternative fuels and various hybrid designs. While BMW recognizes these concerns, there is still much development to be done on the internal combustion engine. Therefore, at least for the time being, BMW will continue to build the some of best internal combustion engines in the world.

Turbocharging Terminology

An engine which does not use any form of “forced induction” is referred to as a “naturally aspirated” engine. This means that the air which is entering the engine is at atmospheric pressure. Atmospheric air enters the engine due to the low pressure created during the intake stroke.

An engine which uses “forced induction” is referred to as supercharged. This means that the air entering the engine is under pressure (above atmospheric). As far as terminology is concerned, supercharging is the broad term for this type of technology.

Supercharging can be broken down into two categories, those engines which use a mechanical supercharger and those which use an exhaust driven turbocharger. Today, BMW is only using turbochargers.

Basic Principles of Turbocharging

In order to make an engine more efficient, it is necessary to ensure an adequate supply of air and fuel on the intake stroke. This mixture can then be compressed and ignited to create the desired engine power output. A normally aspirated engine relies on the basic principle of gas exchange without the use of forced induction.

The volumetric efficiency refers to the ratio between the theoretical cylinder volume and the actual amount of air (and fuel) filling the cylinder during the intake stroke. A naturally aspirated engine has a volumetric efficiency of between 0.6 and 0.9 (60-90%). With the turbocharged engine, volumetric efficiency can peak at over 100%.

A turbocharger is driven by waste (exhaust) gasses and in turn drives a compressor which forces air into the engine above atmospheric pressure. This increase pressure allows for an air charge with a greater density. The result is increased torque and horsepower.

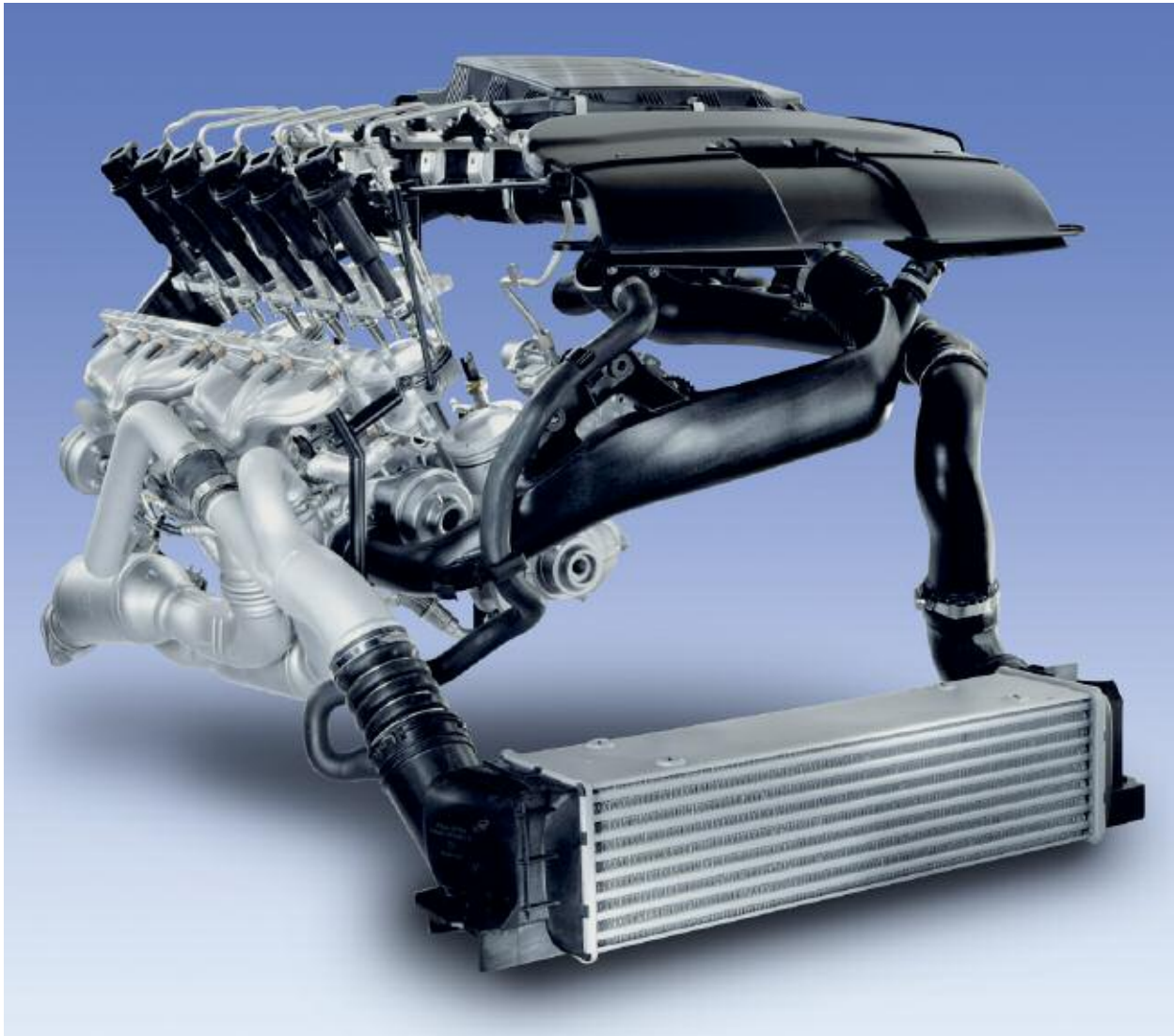

The turbocharger consists of a turbine and compressor assembly (1) on a common shaft inside of the turbocharger housing. The turbine wheel is driven by waste exhaust gases and in turn drives the compressor wheel.

The compressor forces air into the intake manifold of the engine. The air entering the engine from the compressor is above atmospheric pressure. The increased atmospheric pressure allows for an air-charge that is more dense and therefore contains more oxygen.

This increased density during the intake stroke ultimately adds up to the creation of more engine output torque. Of course, this increased density must be accompanied by additional fuel to create the desired power. This is accomplished by engine management system programming to increase injector “on-time” and enhanced associated maps.

To prevent the turbocharger from providing too much boost, a “wastegate” (6) is added to allow exhaust to bypass the turbine. This provides a means of control for the turbocharger system. The wastegate is usually actuated by a vacuum diaphragm (6) which is controlled via vacuum fed from solenoids. These solenoids are typically controlled by the engine management system.

Once the intake air is compressed, it is also heated which is not desirable for maximum efficiency. To counter this situation a heat exchanger (2) is added between the compressor and the engine intake. This heat exchanger is commonly referred to as an intercooler. The intercooler is usually an air-to-air heat exchanger which is installed in the air stream ahead of the radiator (direct charge air cooling) or air to coolant heat exchanger (indirect charge air cooling). Regardless of the type, the intercooler lowers the intake air charge to achieve the maximum density possible.

The use of an exhaust driven turbocharger is used to create more engine power through increased efficiency. In the case of the most current BMW engines, the turbocharger is used in conjunction with direct fuel injection. This provides the best combination of efficiency and power with no compromise.

Turbocharging principles

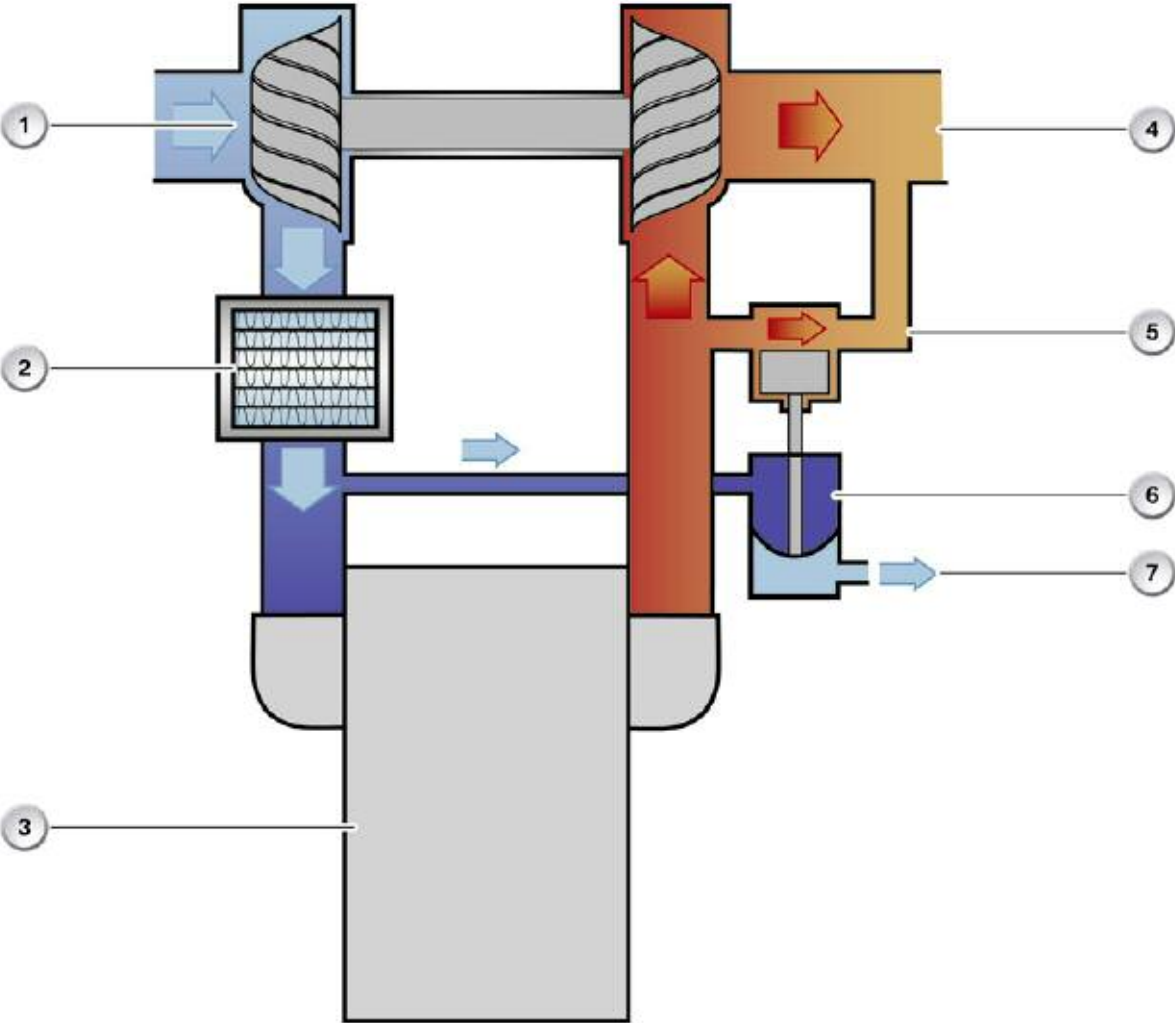

Index	Explanation	Index	Explanation
1	Compressor and turbine wheel (on common shaft)	5	Exhaust bypass from wastegate
2	Charge air cooler (intercooler)	6	Wastegate (and diaphragm)
3	Engine	7	Vacuum control for wastegate diaphragm
4	Exhaust outlet from turbine housing		

N54 turbocharger

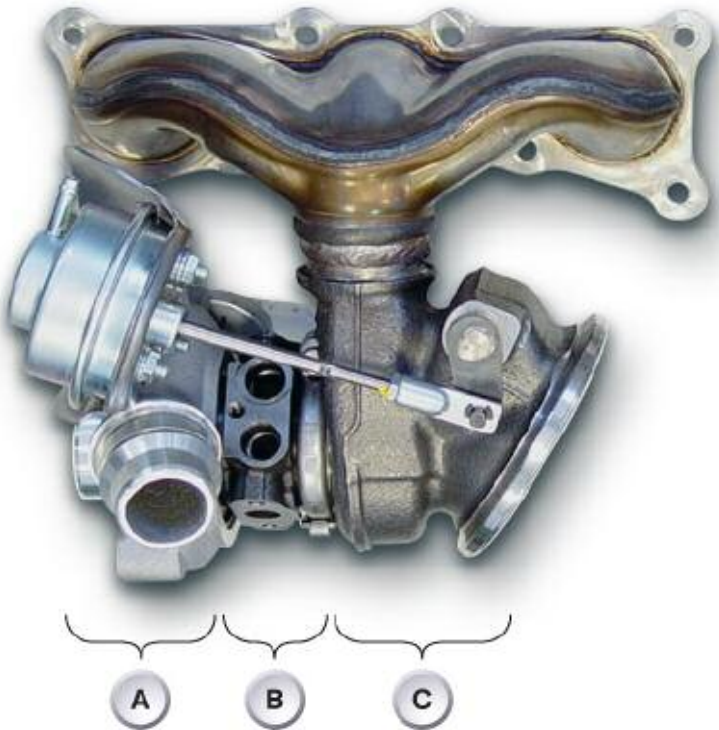

Index	Explanation
A	Compressor
B	Cooling/lubrication
C	Turbine

Bi-turbocharging

The induction air is precompressed in such a way that a higher air mass is admitted into the engine's combustion chamber. In this way, it is possible to inject and combust a greater quantity of fuel, which increases the engine's power output and torque.

The turbine and the compressor can rotate at speeds of up to 200,000 rpm. The exhaust inlet temperature can reach a maximum of 1050°C. Because of these high temperatures, turbochargers are not only connected with the engine-oil system but also integrated in the engine-coolant circuit.

By operating an electric coolant pump even after the engine has been switched off it is possible to dissipate the residual heat from the turbochargers and thus prevent the oil in the bearing housing from overheating.

Utmost importance is attached to turbochargers response characteristics. A delayed response to the driver's command, i.e. the accelerator-pedal position, is not acceptable. The driver therefore must not experience any so-called "turbo lag".

This requirement is met in the N54 engine with two small turbochargers, which are connected in parallel. Cylinders 1, 2 and 3 (bank 1) drive the first turbocharger (5) while cylinders 4, 5 and 6 (bank 2) drive the second (2).

The advantage of a small turbocharger lies in the fact that, as the turbocharger runs up to speed, the lower mass of the turbine allows it to accelerate quicker, and thus the compressor attains a higher boost pressure in a shorter amount of time.

N54 exhaust manifolds, turbos and related components

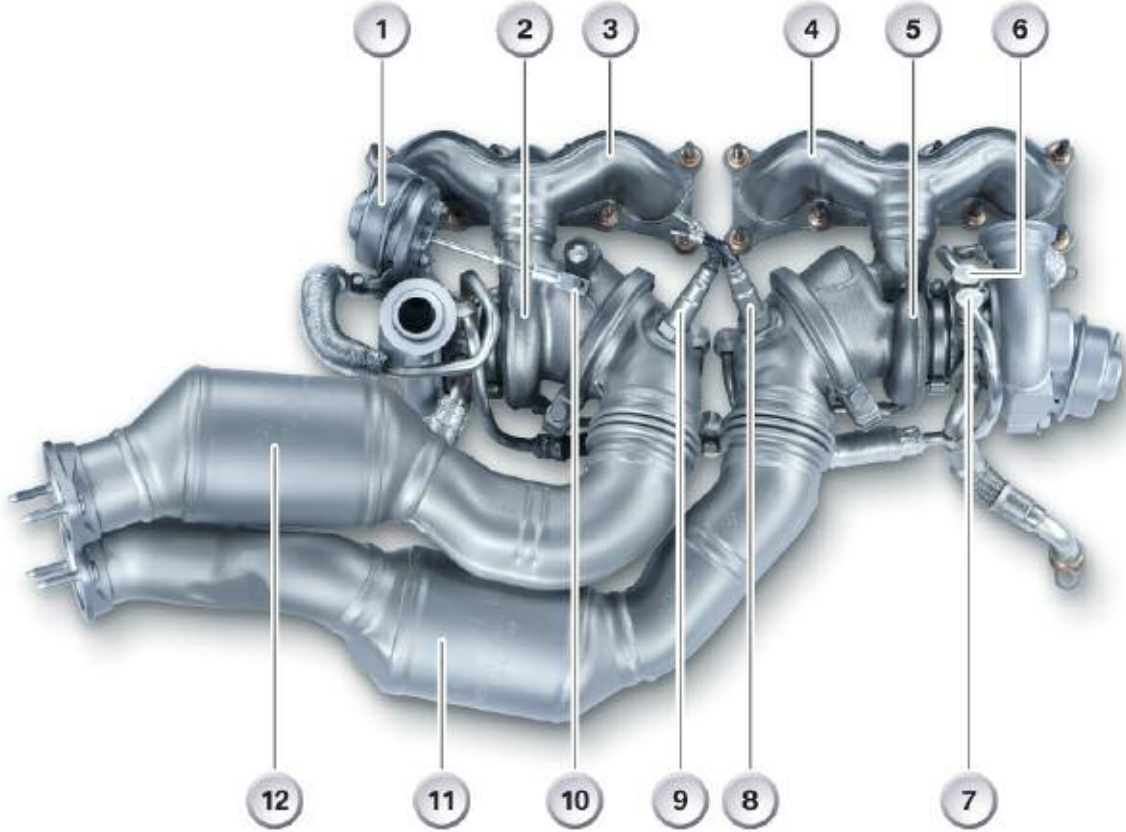

Index	Explanation	Index	Explanation
1	Wastegate actuator, bank 2	7	Coolant supply
2	Turbocharger, bank 2	8	Planar broad-band oxygen sensor, bank 1
3	Exhaust manifold, bank 2	9	Planar broad-band oxygen sensor, bank 2
4	Exhaust manifold, bank 1	10	Wastegate actuating lever
5	Turbocharger, bank 1	11	Catalytic converter, bank 1
6	Coolant return	12	Catalytic converter, bank 2

Air Ducting Overview

The fresh air is drawn in via the air cleaner (10) and the charge-air suction lines (6 + 18) by the compressors of turbochargers (23 + 24) and compressed.

Because the turbochargers can get very hot during operation, they are connected with the engine's coolant and engine-oil circuits. The charge air is greatly heated when compressed in the turbocharger, making it necessary for the air to be cooled again in an intercooler (16).

The compressed and cooled charge air is routed from the intercooler via the throttle valve (12) into the intake manifold. The system is equipped with several sensors and actuators in order to ensure that the load of fresh air is optimally adapted to the engine's respective operating conditions.

N54 forced induction overview

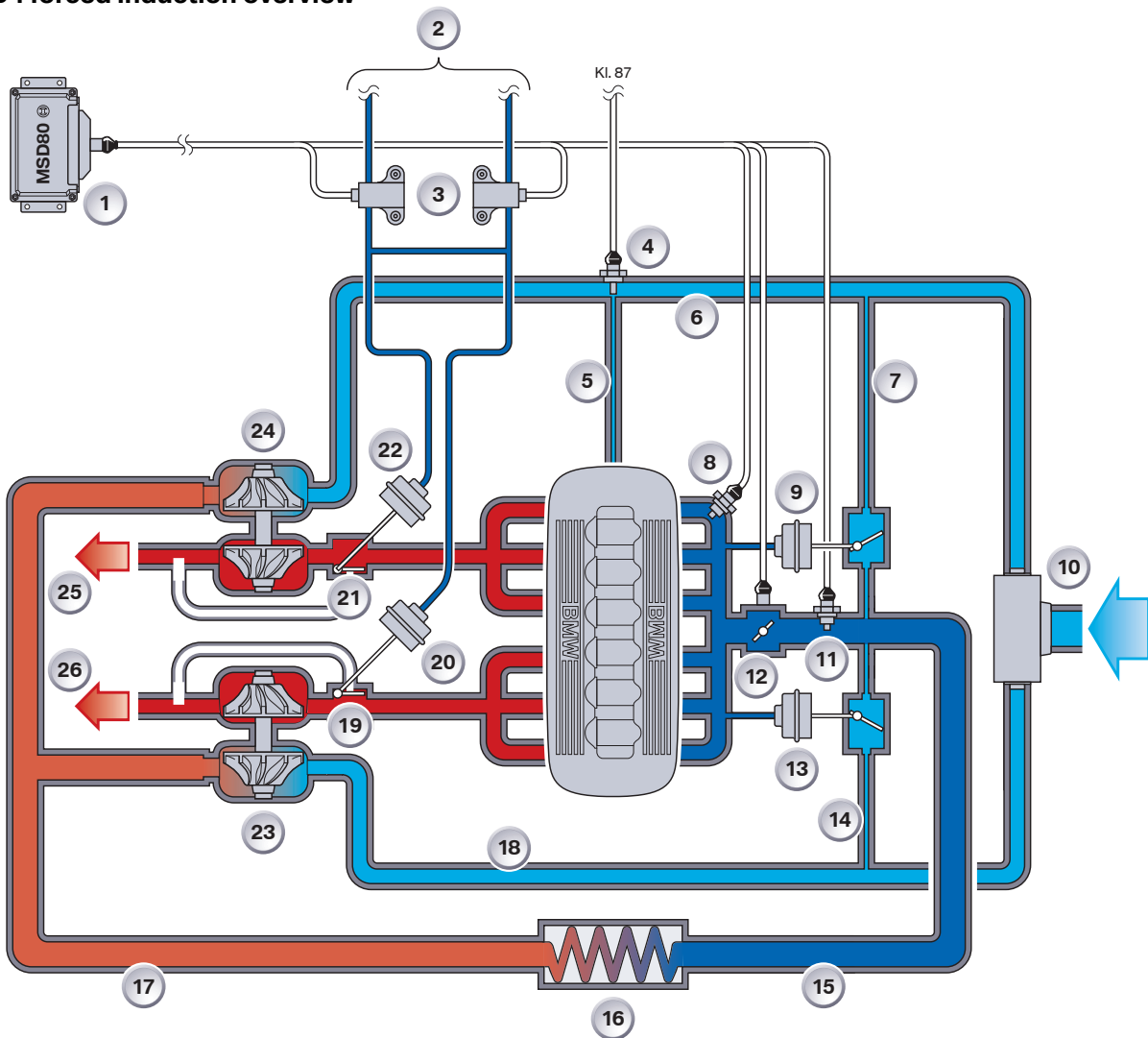

N54 forced induction overview legend

Index	Explanation	Index	Explanation
1	MSD80 Engine control module	14	Recirculated-air line, bank 1
2	Lines to vacuum pump	15	Charge air pressure line
3	Electro-pneumatic pressure transducer	16	Intercooler
4	heater, blow-by gases	17	Charge air manifold
5	Blow-by line turbocharged operation mode	18	Charge air suction line, bank 1
6	Charge air suction line, bank 2	19	Wastegate flap, bank 1
7	Recirculated-air line, bank 2	20	Wastegate actuator, bank 1
8	Intake manifold pressure sensor	21	Wastegate flap, bank 2
9	Blow-off valve, bank 2	22	Wastegate actuator, bank 2
10	Air cleaner	23	Turbocharger, bank 1
11	Charge air pressure and temperature sensor	24	Turbocharger, bank 2
12	Throttle valve	25	To catalytic converter, bank 2
13	Blow-off valve, bank 1	26	To catalytic converter, bank 1

Boost-pressure Control (Wastegate)

The boost pressure of the turbochargers is directly dependent on the flow of exhaust gas which reaches the turbocharger turbines. Both the velocity and the mass of the exhaust-gas flow are directly dependent on engine speed and engine load.

The engine-management system uses **wastegate valves** to control the boost pressure. These valves are operated by vacuum-pressure actuators, which are controlled via electropneumatic pressure transducers by the engine-management system.

The vacuum pressure is generated by the permanently driven vacuum pump and stored in a pressure accumulator. The system is designed to ensure that these loads and consumers do not have a negative influence on the brake-booster function.

The exhaust-gas flow can be completely or partially directed to the turbine wheel with the wastegate valves. When the boost pressure has reached its desired level, the wastegate valve begins to open and direct part of the exhaust-gas flow past the turbine wheel. This prevents the turbine from further increasing the speed of the compressor. This control option allows the system to respond to various operating situations.

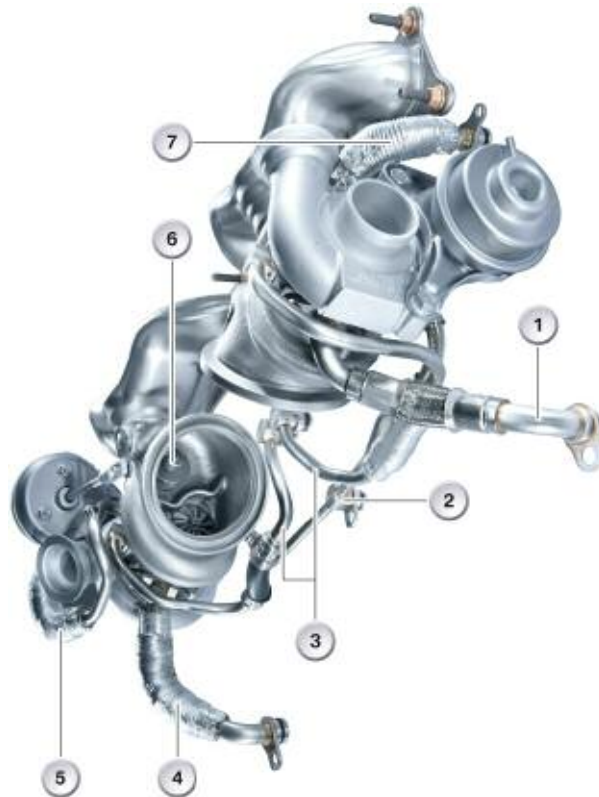

Index	Explanation	Index	Explanation
1	Oil return, bank 1	5	Coolant return, bank 2
2	Oil supply	6	Wastegate valve
3	Coolant supply	7	Coolant return, bank 1
4	Oil return, bank 2	8	

In the idle phase, the wastegate valves of both turbochargers are closed. This enables the full exhaust-gas flow available to be utilized to speed up the compressor already at these low engine speeds.

When power is then demanded from the engine, the compressor can deliver the required boost pressure without any noticeable time lag. In the full-load situation, the boost pressure is maintained at a consistently high level when the maximum permissible torque is reached by a partial opening of the wastegate valves. In this way, the compressors are only ever induced to rotate at a speed which is called for by the operating situation.

The process of the wastegate valves opening removes drive energy from the turbine such that no further increase in boost pressure occurs, which in turn improves overall fuel consumption.

At full-load the N54 engine operates at an overpressure of up to **0.8 bar** in the intake manifold.

Blow-off Control (Diverter Valves)

The blow-off valves in the N54 engine reduce unwanted peaks in boost pressure which can occur when the throttle valve closes quickly. They therefore have an important function with regard to engine acoustics and help to protect the turbocharger components.

A vacuum pressure is generated in the intake manifold when the throttle valve is closed at high engine speeds. This leads to a build-up of high dynamic pressure after the compressor which cannot escape because the route to the intake manifold is blocked.

This leads to a "pumping up" of the turbocharger which means that:

- a clearly noticeable, disruptive pumping noise can be heard,
- and this pumping noise is accompanied by a component-damaging load being exerted on the turbocharger, since high-frequency pressure waves exert axial load on the turbocharger bearings.

N54 Diverter (Blow-off) valves

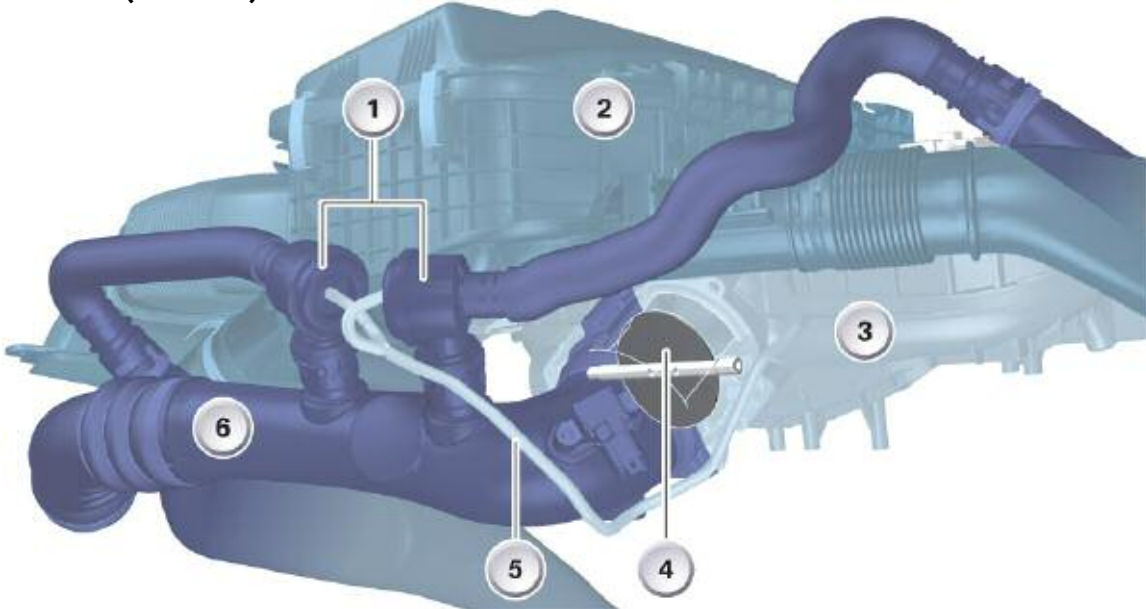

Index	Explanation	Index	Explanation
1	Blow-off valves	4	Throttle valve
2	Air cleaner (ambient pressure)	5	Control line, blow-off valves
3	Intake manifold	6	Charge air pressure line

The blow-off valves are mechanically actuated spring-loaded diaphragm valves which are activated by the intake-manifold pressure as follows:

In the event of a pressure differential before and after the throttle valve, the blow-off valves are opened by the intake-manifold pressure and the boost pressure is diverted to the intake side of the compressor. The blow-off valves open starting from a differential pressure of **0.3 bar**. This process prevents the disruptive and component-damaging pumping effect from occurring.

The system design dictates that the blow-off valves are also opened during operating close to idle (pressure differential $P_{charger}/P_{suction} = 0.3 \text{ bar}$). However, this has no further effects on the turbocharging system.

The turbocharger is pressurized with the full exhaust-gas flow at these low speeds and already builds up a certain level of induction-air precharging in the range close to idle. If the throttle valve is opened at this point, the full boost pressure required is very quickly made available to the engine.

One of the major advantages of the vacuum pressure-actuated wastegate valves is that they can be partially opened in the mid-range in order not to allow excessive induction-air precharging to the detriment of fuel consumption. In the upper load range, they assume the required control position corresponding to the necessary boost pressure.

The diverter valves in the **N63** engine also reduce unwanted peaks in boost pressure which can occur when the throttle valve closes quickly. They therefore have an important function with regard to engine acoustics and help to protect the turbocharger components. As with the N54 a vacuum is generated in the intake manifold when the throttle valve is closed at high engine speeds. This leads to a build-up of high dynamic pressure after the compressor which cannot escape because the route to the intake manifold is blocked.

N63 Diverter valve operation

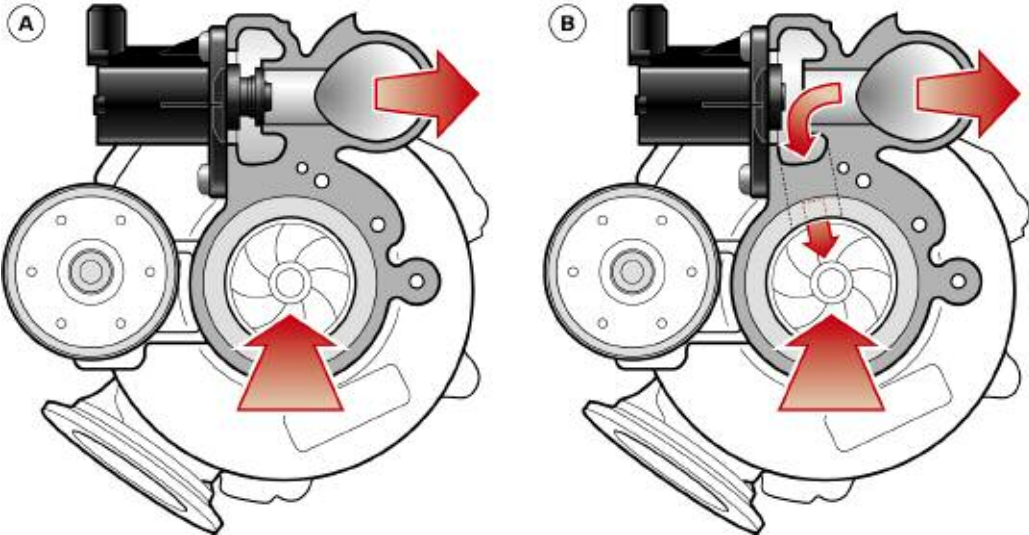

Index	Explanation	Index	Explanation
1	Diverter valve, closed	2	Diverter valve, open

This leads to a "pumping up" of the turbocharger.

In contrast with the N54, the diverter valves on the N63 engine are electrically operated valves. When the throttle valve closes, the boost pressure (upstream of the throttle valve) and its increase are compared with stored target values.

The diverter valves are opened if the actual values exceed the target by a certain value. As a result, the boost pressure is diverted to the intake side of the compressor.

This procedure prevents the disruptive and component-damaging pumping effect from occurring.



Diverter valve on the N63



On N55 and N74 the diverter valve is located on the compressor housing. See twin-scroll turbo section for more information.

Charge Air Cooling

Direct Charge Air Cooling

Cooling the charge air in the N54 engine serves to increase power output as well as reduce fuel consumption. The charge air heated in the turbocharger by its component temperature and by compression is cooled in the intercooler by up to 80°C.

This increases the density of the charge air and improves the charge in the combustion chamber. This translates in lower boost pressure required which in turn reduces the risk of knock which improves engine efficiency.

N54 Direct charge air cooling (air to air)



The N55 Uses Direct Charge Air Cooling (air to air) as on N54.

Indirect Charge Air Cooling

Indirect charge air cooling was used for the first time on the N63 engine.

The charge air is cooled by means of an air-to-coolant heat exchanger. Therefore, the N63 engine features a separate self contained low-temperature coolant circuit.

The charge air heated in the turbocharger by its component temperature and by compression is cooled in the intercooler by up to 80°C. This results in increased power output and reduced fuel consumption.

As with direct charge air cooling, the increased density of the charge air improves the charge in the combustion chamber and results in lower boost pressure required which reduces the risk of knock improves engine efficiency.

Indirect charge air cooling has the advantage of requiring little space as the system can be mounted directly on the engine. Due to the near-engine installation position, the distinctly shorter pipe length required for charge air routing also have a positive effect.

In this way, pressure loss has been substantially reduced, thus improving power yield and engine response.

N63 Indirect charge air cooling (air to coolant)

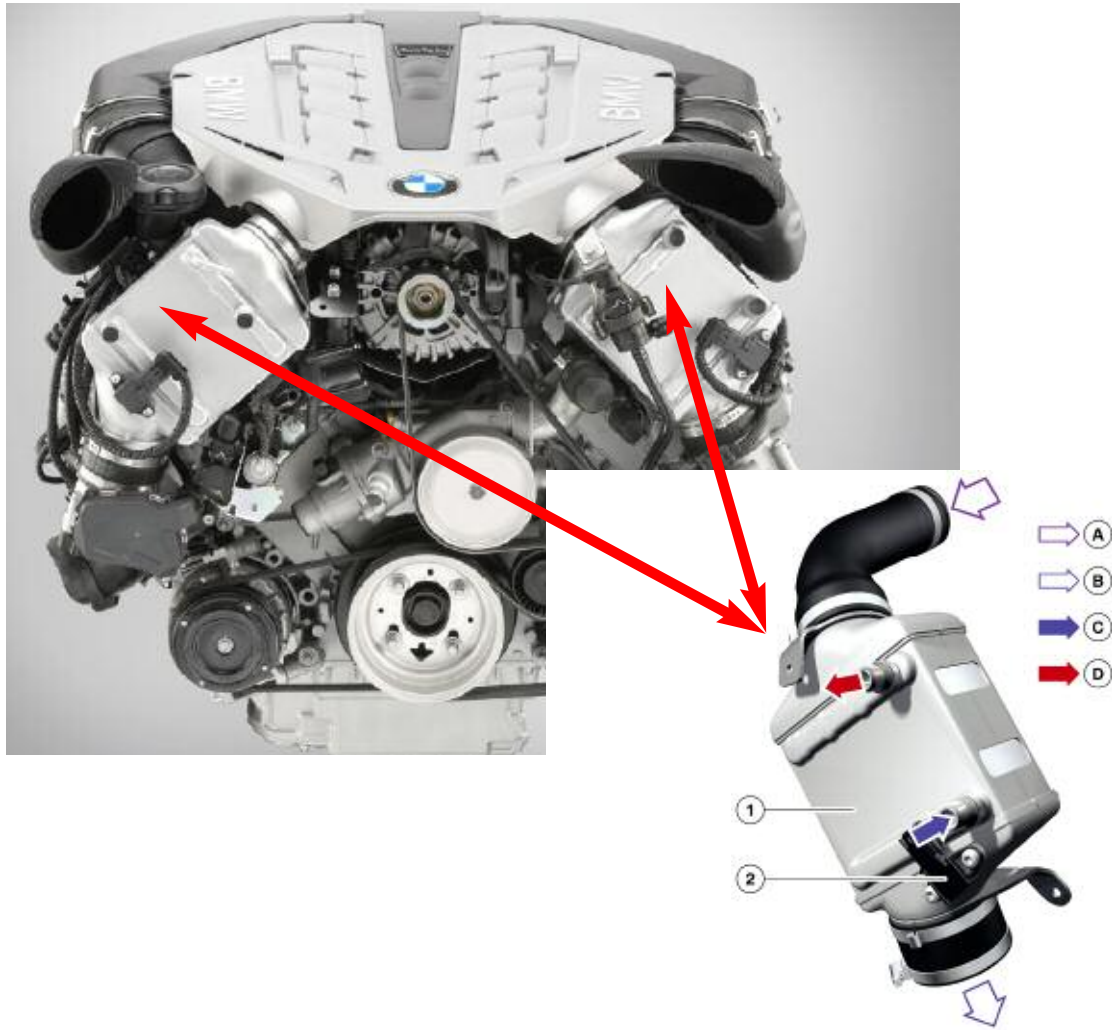

Index	Explanation	Index	Explanation
A	Hot charge air	D	Hot coolant
B	Cooled charge air	1	Intercooler
C	Cooled coolant	2	Charge air pressure/temperature sensor



The N74 Uses Indirect Charge Air Cooling (air to coolant) as on N63.

Twin Scroll Turbocharger

The N55 is equipped with a single twin scroll turbocharger instead of two separate small turbochargers as on the N54 engine. The following graphics show the operating principle of the twin scroll turbocharger.

Twin scroll turbocharger rear view

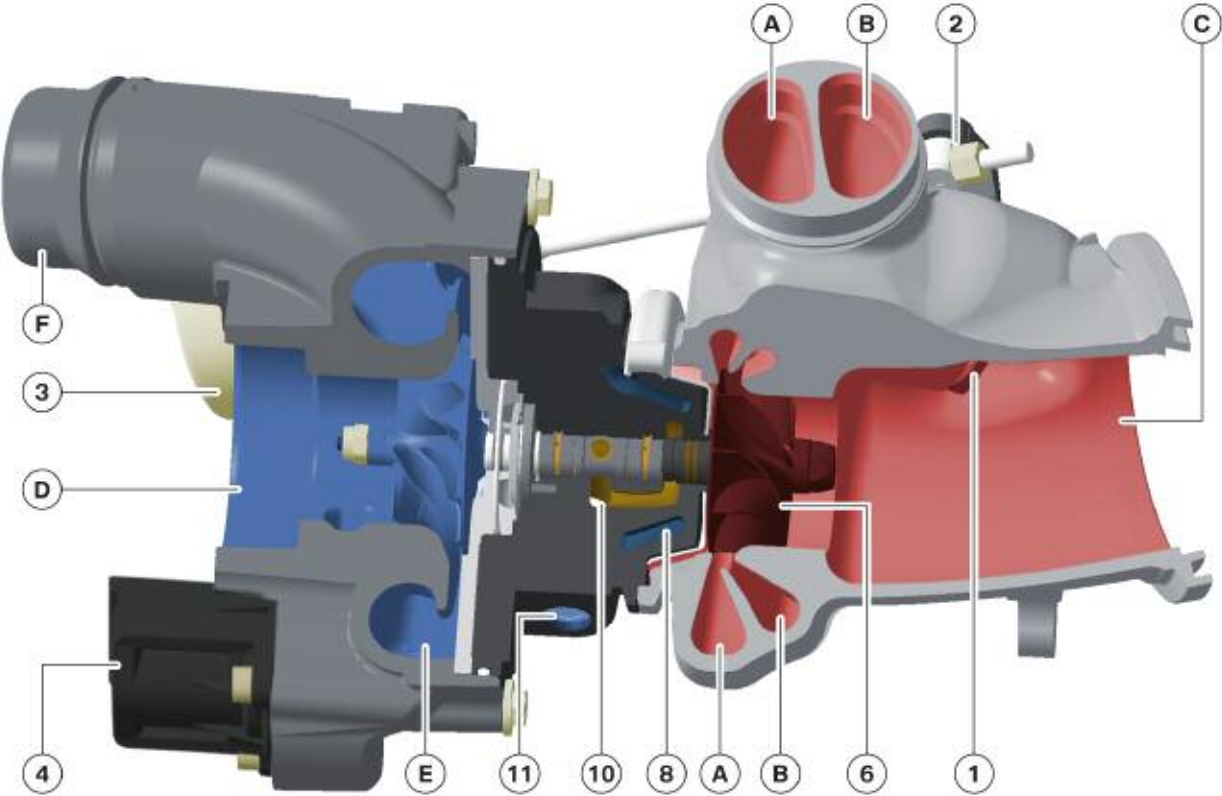

Index	Explanation	Index	Explanation
A	Exhaust duct 1 (cylinders 1 - 3)	2	Lever arm, wastegate valve
B	Exhaust duct 2 (cylinders 4 - 6)	3	Vacuum unit for wastegate valve
C	Connection to catalytic converter	4	Diverter valve
D	Inlet from intake silencer	6	Turbine wheel
E	Ring channel	8	Cooling duct
F	Outlet to intercooler	10	Oil return
1	Wastegate valve	11	Coolant return

Twin scroll turbocharger front view

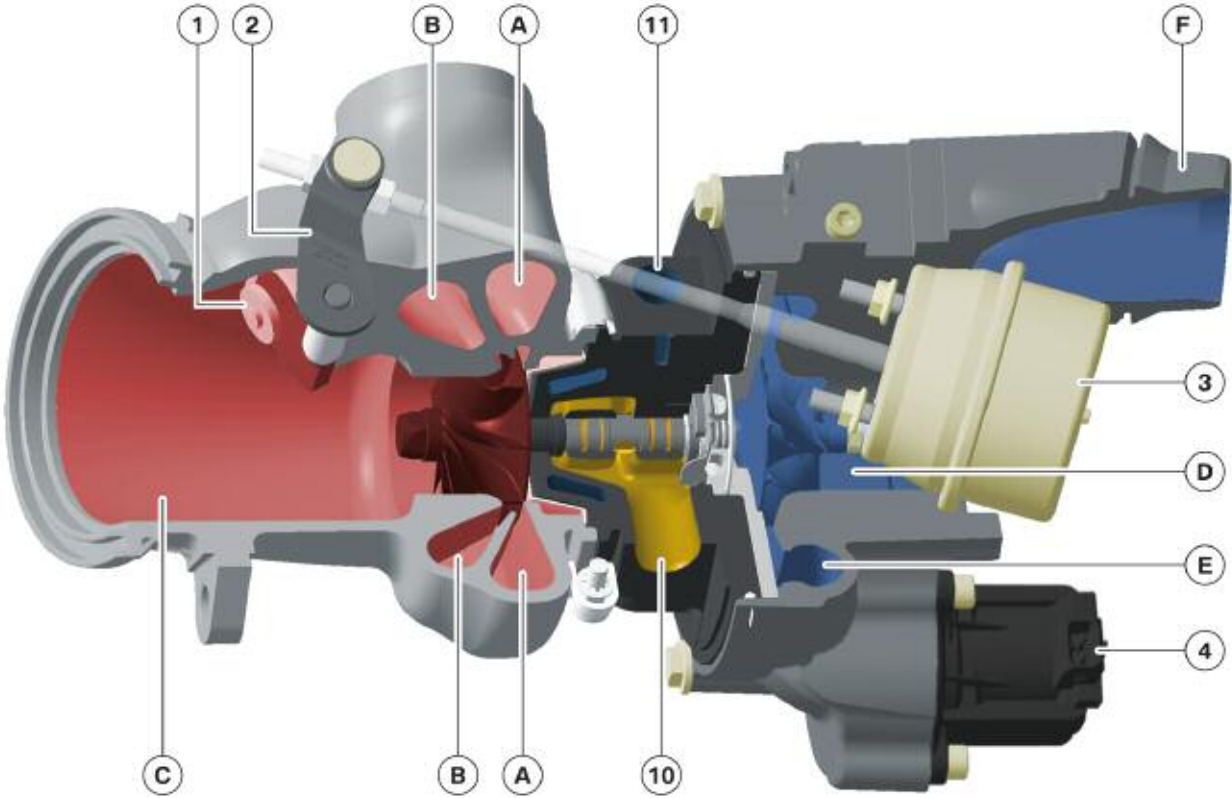

Index	Explanation	Index	Explanation
A	Exhaust duct 1 (cylinders 1 - 3)	1	Wastegate valve
B	Exhaust duct 2 (cylinders 4 - 6)	2	Lever arm, wastegate valve
C	Connection to catalytic converter	3	Vacuum unit for wastegate valve
D	Inlet from intake silencer	4	Diverter valve
E	Ring channel	10	Oil return
F	Outlet to intercooler	11	Coolant return

Function of the Twin Scroll Turbocharger

The system is designed so that constant exhaust gas pressure is nearly applied to the turbocharger. At low engine speeds, the exhaust reaches the turbine in tuned pulsed form. Due to this pulsation, a higher pressure ratio is temporarily reached in the turbine. Since the efficiency increases as the pressure rises, the pulsation improves the boost pressure progression and thus the torque progression of the engine. This is the case particularly at low engine speeds.

The response characteristics of the twin scroll turbocharger are enhanced when compared to a single scroll setup. The turbocharger turbines are fed through two separate channels within the turbine housing (highlighted red in the graphic above). Each of these channels or “scrolls” is always fed by the exhaust pulses from the same two cylinders.

To limit the back pressure and ensure that the individual cylinders do not mutually influence each other during the cylinder charging process, cylinders 1 - 3 (bank 1) and cylinders 4 - 6 (bank 2) are combined to form two exhaust channels. The exhaust gas pulses in the exhaust channels (1 and 2) are directed into two scrolls (spirals) within the turbocharger to drive the turbine wheel. This design layout makes it possible to optimally use the exhaust pulsations for generating boost pressure based on the firing order of the engine. This improves engine efficiency by enhancing throttle response and limiting unwanted turbo lag.

The wastegate valve is used for the purpose of limiting the boost pressure and is already known from previous BMW turbo engines. It is vacuum operated and electronically controlled through a vacuum control solenoid by the DME (ECM).

■ Diverter valve

The basic function of the diverter valve remains the same. The difference compared to the N54 engine is that the diverter valve is not operated pneumatically. The diverter valve on the N55 engine is an electric actuator that is controlled directly by the DME. As with N74 the number of components has been greatly reduced by positioning the diverter valve on the turbocharger compressor housing.

The diverter valve is designed to release unwanted pressure in the intake by connecting the pressure side of the induction system to the inlet side under deceleration. The undesirable peaks in the boost pressure that can occur when the throttle valve is quickly closed are reduced. This means the diverter valve plays an important role in terms of the engine acoustics while protecting the components of the turbocharger.



For further information regarding the N55 engine refer to the N55 training material available on TIS and ICP.

Tuned Pulsed Exhaust Manifold

The exhaust manifold is air-gap insulated and designed as a six ports into two chamber manifold. Dividing six exhaust ports into two exhaust chambers is necessary in order to ensure optimum flow to the twin scroll turbocharger. The exhaust pulses from the first three cylinders (1-3) feed one scroll (duct 1) of the turbo, while the last three (4-6) feed the second scroll (duct 2). The exhaust manifold and turbocharger are welded together to form one component.

N55, attachment of exhaust manifold and turbocharger to engine block

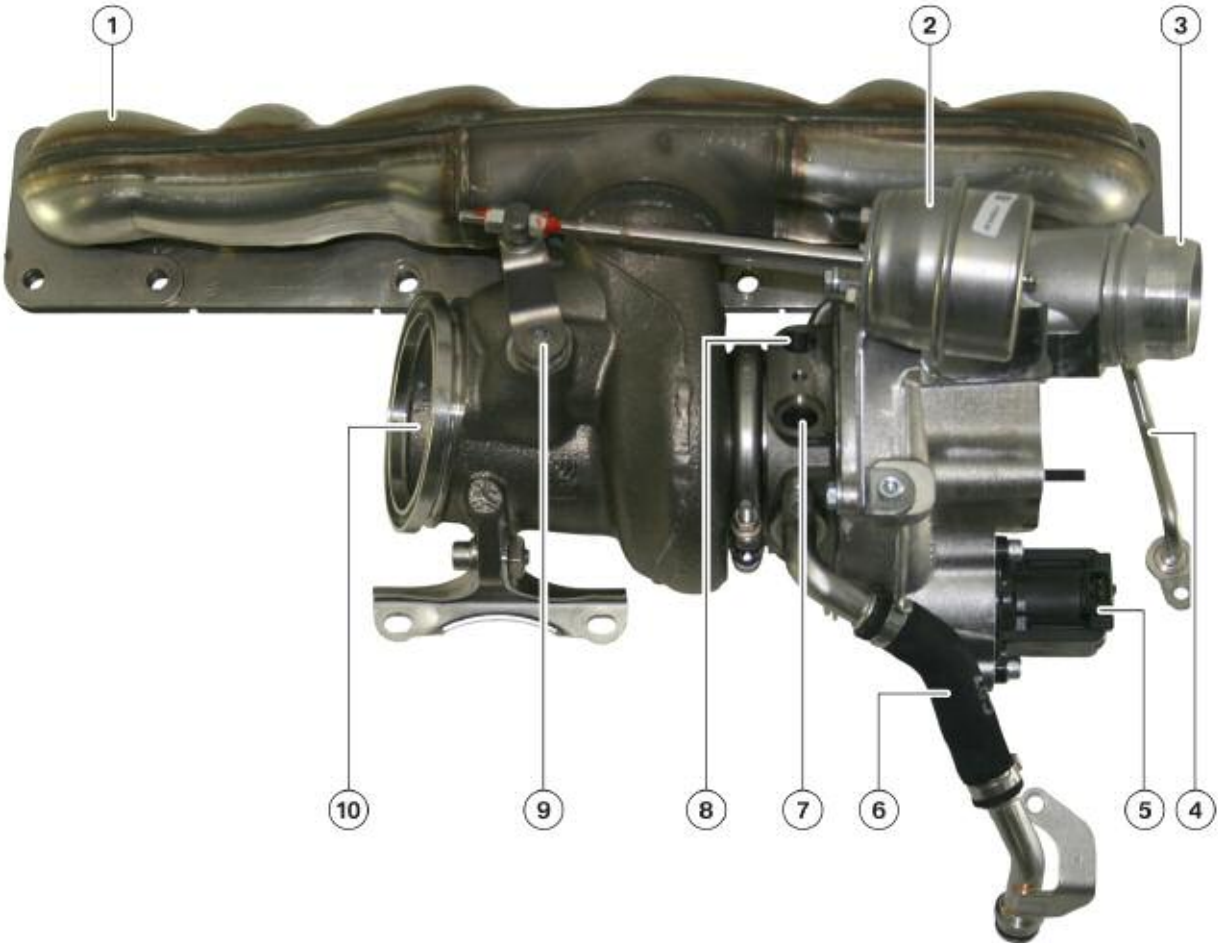

Index	Explanation	Index	Explanation
1	Exhaust manifold	6	Oil return line
2	Vacuum unit	7	Coolant infeed
3	Connection to intercooler	8	Coolant return
4	Oil feed line	9	Shaft, wastegate valve
5	Diverter valve	10	Connection to exhaust system

Load Control

Load control is effected by means of the throttle valve and the waste gate valves.

The throttle valve is the primary component in this process. The wastegate valves are actuated to bring about a fine tuning of the boost pressure. At full load the throttle valve is completely open and load control is undertaken by the wastegate valves.

The load-control graphic shows that the wastegate valves are integrated in load control in all operating situations of the N54 engine on the basis of map control.

Load Control Overview

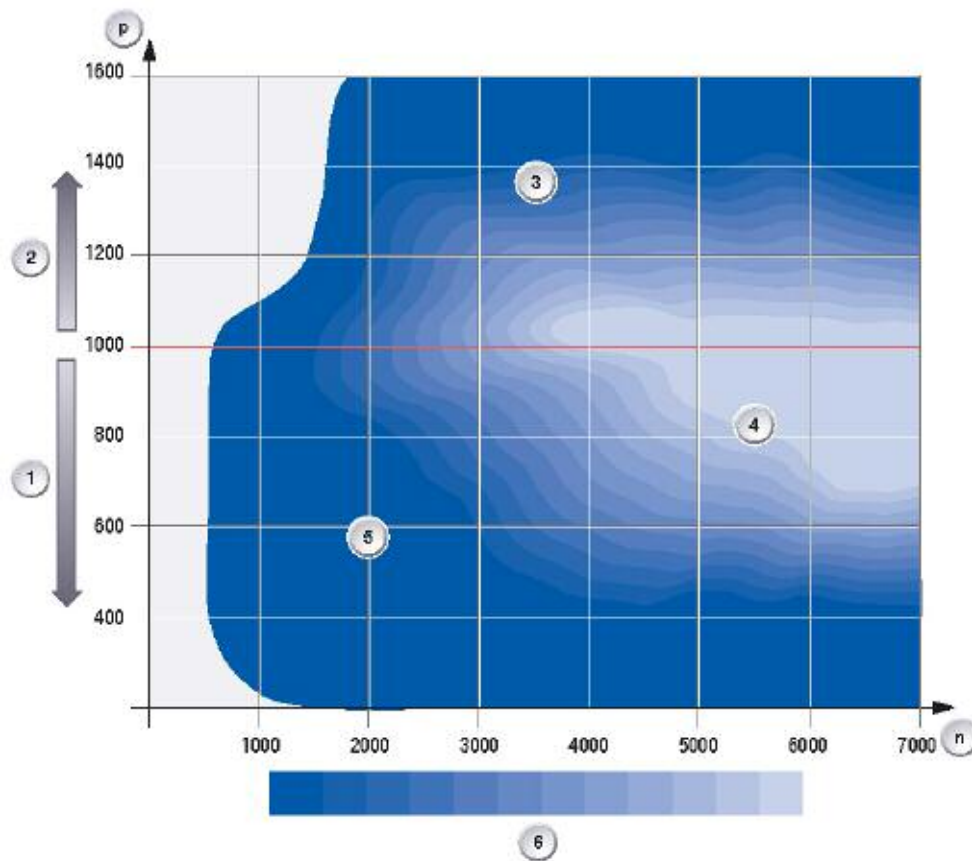

Index	Explanation	Index	Explanation
n	Engine speed in RPM	3	Wastegate controlled as a function of boost pressure
p	Absolute pressure in the intake in millibar	4	Wastegate partially opened
1	Naturally aspirated engine operation	5	Wastegate closed
2	Turbocharged operation	6	Dark = Wastegate fully closed Light = Wastegate fully open

Controlled Variables

The following variables, among others, influence control of the engine's boost pressure:

- Intake-air temperature
- Engine speed
- Throttle-valve position
- Ambient pressure
- Intake-manifold pressure
- Pressure before the throttle valve (reference variable)

The electropneumatic pressure transducers are activated by the engine control unit on the basis of these variables. The result of this activation can be checked from the boost pressure achieved, which is measured before the throttle valve.

There follows a comparison of the boost pressure achieved with the setpoint data from the program map, which can if necessary give rise to an activation correction. The system therefore controls and monitors itself during operation.

Service Information

Limp-home Mode

In the event during operation of malfunctions, implausible values or failure of any of the sensors involved in turbocharger control, activation of the wastegate valves is shut down and the valve flaps are thus fully opened. Turbocharging ceases at this point.

The list below sets out those components or functional groups in which a failure, a malfunction or implausible values result in boost-pressure control being deactivated. The driver is alerted to a fault of this type via an EML indication.

- High-pressure fuel system
- Inlet VANOS
- Exhaust VANOS
- Crankshaft sensor
- Camshaft sensor
- Boost-pressure sensor
- Knock sensors
- Intake-air temperature sensor

One principle of vehicle repair is particularly important in this respect:

It is important to focus on the causes rather than the effects.

With regard to the diagnosis and subsequent repair of turbocharging components, it is important to ensure that they are also actually identified as defective components with the diagnostic technology available.

It is always vital to ensure that the cause of the fault is determined and rectified and that if necessary work is not carried out on symptoms of fault consequences.

Thus, for instance, a leaking flange on the intercooler can have far-reaching consequences.

When diagnosing a turbo complaint always follow the three golden rules of procedure:

1. Do not rashly trace loss of power and engine malfunctions back to the turbocharger. To avoid the replacement of turbochargers which are in perfect working order, the following should be observed:

When blue smoke emerges from the exhaust system, check whether the air cleaner is contaminated or the engine is consuming too much oil because of wear. Or, if the crankcase ventilation system is faulty. Only then resort to checking the turbocharger. If the turbocharger is running too loud, inspect all the connections on the turbocharger pressure side. If black smoke or a loss of power is detected, in this case too check the engine and the connecting pipes first.

2. Main causes of turbocharger damage:
 - Insufficient lubrication and consequently bearing failure. Compressor and turbine wheels will grind in the housings, the seals will be damaged and the shaft may also shear off.
 - Foreign bodies damage the turbine and impeller. The resulting imbalance will reduce efficiency and may cause rotor damage.
 - Contaminated oil causes scoring on shaft journals and bearings. Oilways and seals will become clogged and cause oil leakage. Elements entering the turbocharger system from the outside such as sand, dirt, screws and the like will be trapped by a filter before the compressor.

Service the filters at regular intervals (service intervals). Make sure to keep the clean-air area of the air cleaner and the air ducting to the compressors clean and free from all types of debris.

3. Do not make any alterations to the turbocharger: Never attempt to alter the boost-pressure control linkage. The turbocharger has been optimally configured at the factory. If the turbocharger operates at higher boost pressures than permitted by the engine manufacturer, the engine may run hot and pistons, cylinder heads or engine bearings may fail, or the safety function of the engine electronics may respond and activate the engine's limp-home program.

Direct Injection

The term “direct injection” refers to a fuel injection system which injects fuel directly into the combustion chamber rather than into the intake manifold. This technology has been around since the 1930’s, but has not been in widespread use until the late 20th century.

The early development of this type of injection system took place in Germany in 1937 on an aircraft engine. The first passenger car to run on direct engine was a car called the “Gutbrod” in the early 50’s.



Due to the complexity and cost of the direct injection system, the technology did not take hold. Later, the development of more cost efficient components and the need for a more efficient internal combustion engine, the DI engine made a comeback in the late 1990’s.

The first application of this technology on a BMW was in 2003 on the 760Li. The new N73 V-12 engine utilized direct injection with the combination of VALVETRONIC and the latest direct injection technology.

For the 2007 model year, BMW introduced the N54 engine with direct fuel injection. It combined (for the first time) turbocharging with the second generation of direct injection (DI 2), referred to as High Precision Injection (HPI).

Direct Injection Principles

As the name suggest, the direct injection (DI) system uses a fuel injector which sprays fuel directly into the combustion chamber. The fuel injection pressure (N73) is from 80 to 120 bar. The A/F mixture in a DI engine is formed inside of the combustion chamber. In comparison, a manifold injection system sprays fuel into the intake manifold or into the intake port near the intake valve. In this case, the A/F mixture is formed outside of the combustion chamber. The injection pressure on most manifold injection systems is between 3 and 5 bar.

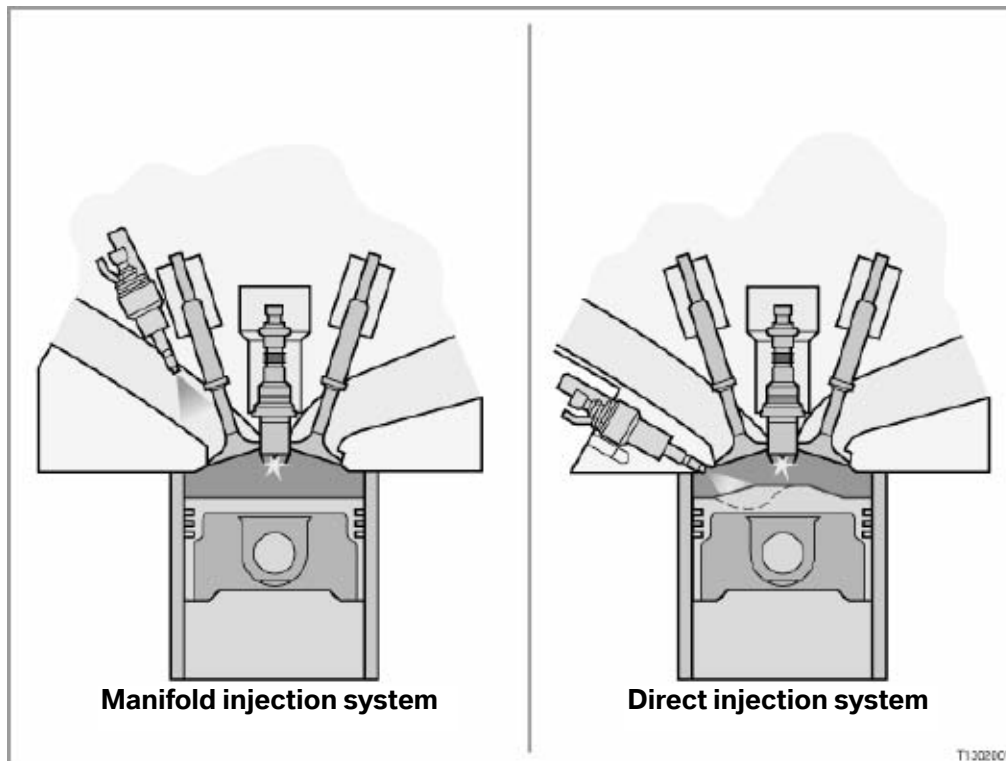

The DI system allows for increased engine efficiency and has several distinct advantages over manifold injection systems:

- The fuel is evaporated and atomized in the combustion chamber, which provides a “cooling effect” on combustion. A cooler combustion chamber allows an increase in air density, which allows for more available oxygen. In addition, cooler combustion allows for an increase in compression ratio which equates to improved efficiency and engine power.
- By injecting the fuel directly into the combustion chamber, there is less possibility for fuel to condense or accumulate on the manifold walls or the back of the intake valve. This results in less fuel needed to achieve the desired A/F ratio.
- The increased injection pressure causes the fuel droplet size to be reduced. This allows for improved atomization and therefore improved mixture formation.

Mixture Formation

In a conventional (manifold injection) engine, the air fuel mixture is formed outside of the combustion chamber. In contrast, the mixture must be formed inside the combustion chamber in a DI engine.

A DI fuel system has two basic operating concepts:

- Homogeneous Mixture Formation** - A homogeneous mixture means that the A/F ratio is stoichiometrically controlled much in the same way as a manifold injection system. This means that the A/F mixture is evenly spread throughout the combustion chamber. One of the primary advantages of this arrangement is that a conventional three-way catalytic converter can be used. Also, the sulfur content of the fuel is not a factor which allows the engine to be used in all global markets. Currently, BMW only uses engines which operate in this mode (mostly at $\text{Lambda} = 1$).
- Stratified Mixture Formation** - In the stratified injection method, a homogeneous mixture is only created around the area of the spark plug. A lean (inhomogeneous) mixture exists in the rest of the combustion chamber. Therefore the overall A/F mixture in the combustion chamber is lean ($\text{lambda} > 1$). This results in increased combustion chamber temperature, and subsequently increased NOx emissions. The increased NOx requires the use of a DeNOx catalyst which is not effective when sulfur is present in the fuel. Therefore, sulfur free fuel must be used which is not readily available in all markets. For the time being, BMW does not have any engines which operate in “stratified charge” in the US market.

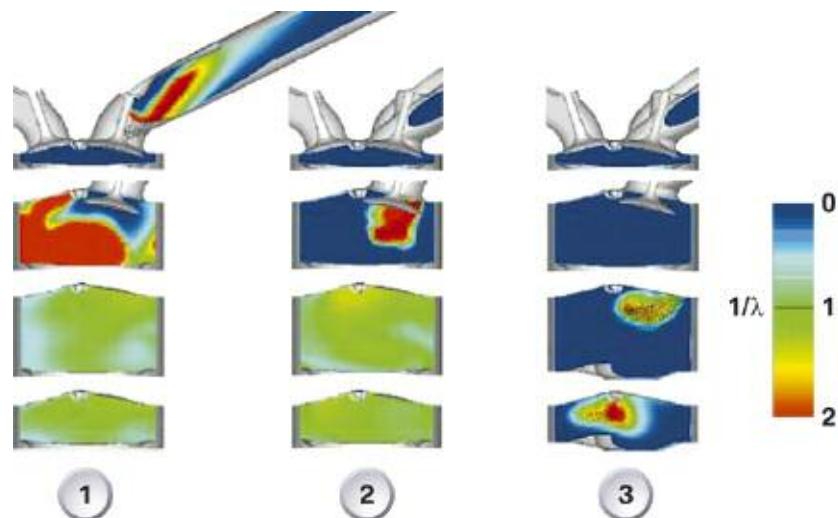

Index	Explanation
1	Manifold injection
2	Homogeneous direct injection
3	Stratified direct injection

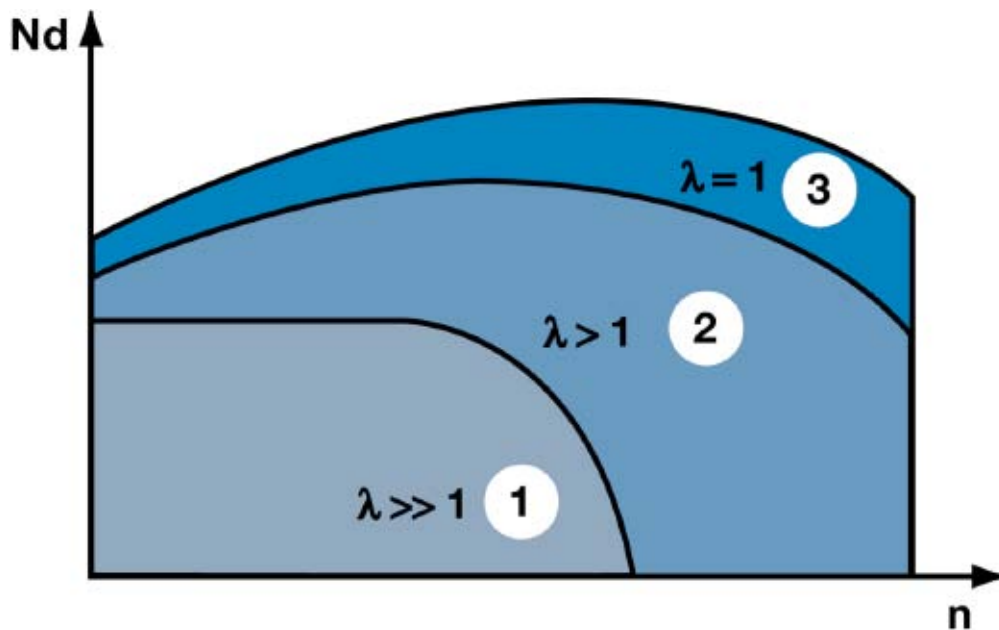

Index	Explanation
1	Lean, charge stratification
2	Lean, homogeneous
3	Homogeneous
Nd	Engine torque
n	Engine speed

As the above chart shows, the use of load stratification (1) is only possible in a limited load and speed range. Over and above this load and speed range, the engines can only be operated in homogeneous mode (2-3).

Through the deployment of VALVETRONIC, the N73 engine in the middle torque/speed range (1) demonstrates the same consumption advantages as engines of other manufacturers with charge stratification.

Because large-capacity engines are mainly operated in the lower to middle load and speed range, it is only advisable to use load stratification in these engines.

Smaller-sized engines are mainly operated in the high load and speed range and thus in homogeneous mode.

Current BMW engines operate mostly in the homogeneous mode with a lambda value of 1. In the US market, BMW does not use a “stratified charge” engine due to the fact that these engines emit high NOx levels.

High Precision Injection

The BMW High Precision Injection (HPI) is the second generation of direct injection (DI 2) for BMW. The first generation was on the N73 engine in 2003. The HPI system was introduced in the N54 and is currently also used on N63, S63 and the N74 V12 engine.

The term “high precision” refers to the precise metering and directional control of the atomized fuel. Also, the injection process now allows for multiple injection events due to the use of piezo injectors. The HPI system represents a key function in the concept for the most economical use of fuel without compromising performance.



High precision injection allows for a more precise metering of the fuel injection process and therefore permits a higher compression ratio of 10.2 to 1. This compression ratio is quite high considering the N54 is turbocharged. However, the “spray guided” injection process cools the air charge and decreases the possibility of unwanted engine knock. The operating pressure of the HPI system is up to 200 bar.

High-precision injection represents the key function in the concept of using the less fuel as possible. The new generation of gasoline direct injection satisfies the expectations placed on it with regard to economic efficiency without compromising the engine's dynamic qualities (Efficient Dynamics).

High-precision injection provides for a more precise metering of mixture and higher compression - ideal preconditions for increasing efficiency and significantly reducing consumption.

This is made possible by locating the piezo injector centrally between the valves. In this position, the new injector (which opens in an outward direction) distributes a particularly uniform amount of fuel into the combustion chamber in a tapered shaped spray pattern.

The new direct injection of BMW HPI spark ignition engines operate according to the spray-guided process.

HPI Function

The fuel is delivered from the fuel tank by the electric fuel pump via the feed line (5) at an “feed” pressure of 5 bar to the high pressure pump. The feed pressure is monitored by the low-pressure sensor (6). The fuel is delivered by the electric fuel pump in line with demand.

If this sensor fails, the electric fuel pump continues to run at 100% delivery with terminal 15 ON.

On N54 and N55 The high pressure pump is driven “in-tandem” with the vacuum pump which is driven by the oil pump chain drive assembly.(See HDE for more information)

The fuel is compressed in the permanently driven three-plunger high-pressure pump (8) and delivery through the high-pressure line (9) to the rail (3). The fuel accumulated under pressure in the rail in this way is distributed via the high-pressure lines (1) to the piezo injectors (2).



The high pressure injection pump on the N63 and N74 is of a more compact design. It is mounted on the cam cover and driven by a triple cam on the exhaust cam on the N63 and by the intake cam on the N74. Please refer to the appropriate training information or repair instructions for more details.



N63 high pressure pump

The required fuel delivery pressure is determined by the engine-management system as a function of engine load and engine speed. The pressure level reached is recorded by the high-pressure sensor (4) and communicated to the engine control unit.

Control is effected by the fuel-supply control valve (7) by way of a setpoint/actual-value adjustment of the rail pressure. Configuration of the pressure is geared towards best possible consumption and smooth running of the engine. 200 bar is required only at high load and low engine speed.

N54 HPI direct injection components

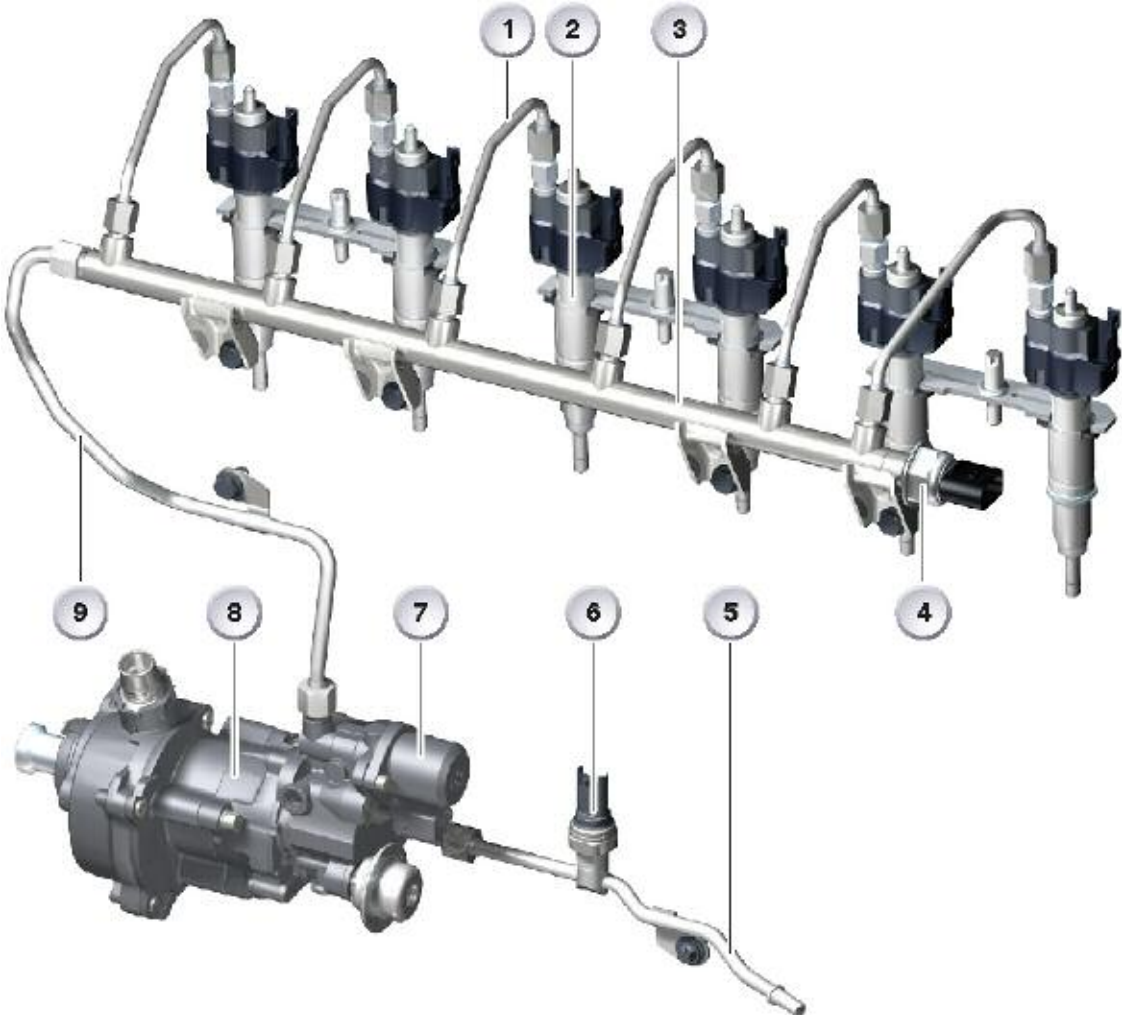

Index	Explanation	Index	Explanation
1	High-pressure line to injector (6)	6	Low-pressure sensor
2	Piezo injector	7	Fuel supply control valve
3	Fuel rail	8	Three plunger high pressure pump
4	High pressure sensor	9	High pressure line (pump to rail)
5	Feed line from in-tank pump		

High Pressure Pump Function and Design

The fuel is delivered via the supply passage (6) at the admission pressure generated by the electric fuel pump to the high-pressure pump. From there, the fuel is directed via the fuel supply control valve (4) and the low-pressure non-return valve (2) into the fuel chamber (14) of the plunger-and-barrel assembly. The fuel is placed under pressure in this plunger-and-barrel assembly and delivered via the high pressure non-return valve (9) to the high pressure port (7).

N54 HPI high pressure pump

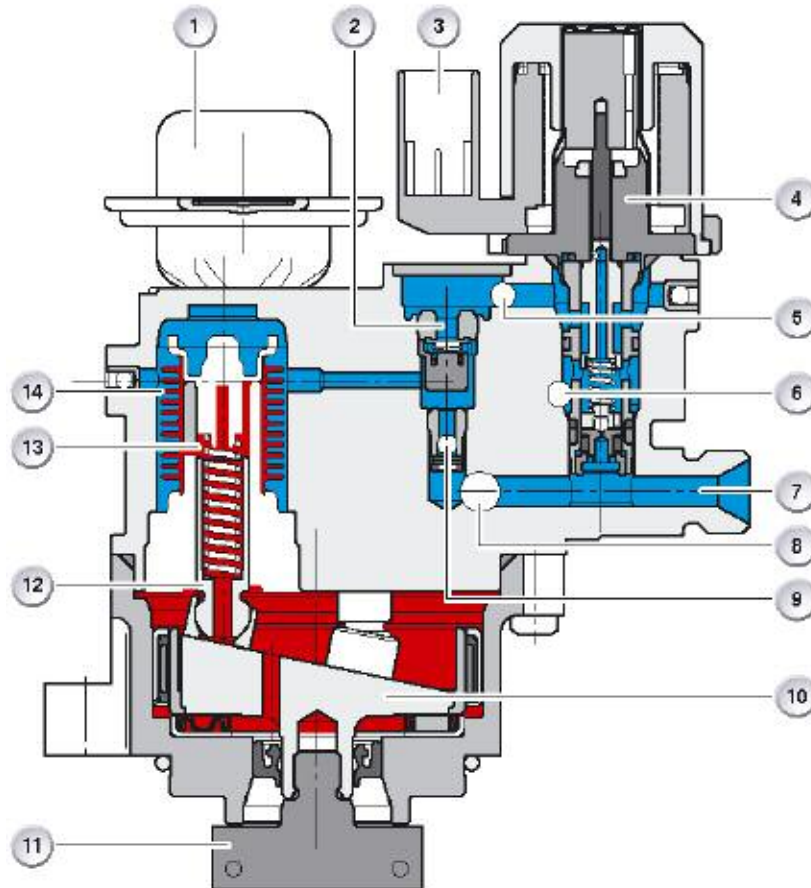

Index	Explanation	Index	Explanation
1	Thermal compensator	8	Supply passage, pressure limiting valve
2	Low pressure non-return valve (check valve)	9	High pressure non-return valve (x 3)
3	Connection to engine management	10	Pendulum disc
4	Fuel supply control valve	11	Drive flange, high pressure pump
5	Return, pressure limiting valve	12	Plunger (x 3)
6	Supply from electric fuel pump (in-tank)	13	Oil filling, high pressure pump
7	High pressure port to fuel rail	14	Fuel chamber (x 3)

The high-pressure pump is connected with the vacuum pump via the drive flange (11) and is thus also driven by the chain drive, i.e. as soon as the engine is running, the three plungers (12) are permanently set into up-and-down motion via the pendulum disc (10).

Fuel therefore continues to be pressurized for as long as new fuel is supplied to the high-pressure pump via the fuel-supply control valve (4). The fuel-supply control valve is activated by means of the engine management connection (3) and thereby admits the quantity of fuel required.

Pressure control is effected via the fuel-supply control valve by opening and closing of the fuel supply channel. The maximum pressure in the high-pressure area is limited to 245 bar. If excessive pressure is encountered, the high-pressure circuit is relieved by a pressure-limiting valve via the ports (8 and 5) leading to the low-pressure area.

This is possible without any problems because of the incompressibility of the fuel, i.e. the fuel does not change in volume in response to a change in pressure. The pressure peak created is compensated for by the liquid volume in the low-pressure area.

Volume changes caused by temperature changes are compensated for by the thermal compensator (1), which is connected with the pump oil filling.

■ Pressure Generation in High-pressure Pump

The plunger (2) driven by the pendulum disc presses oil (red) into the metal diaphragm (1) on its upward travel. The change in volume of the metal diaphragm thereby reduces the available space in the fuel chamber. The fuel thereby placed under pressure (blue) is forced into the rail.

The fuel-supply control valve controls the fuel pressure in the rail. It is activated by the engine management system via a pulsewidth modulated (PWM) signal.

Depending on the activation signal, a restrictor cross-section of varying size is opened and the fuel-mass flow required for the respective load point is set. There is also the possibility of reducing the pressure in the rail.

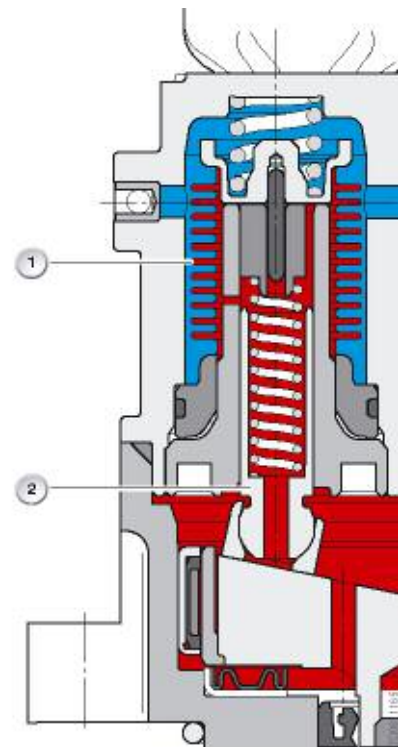

Index	Explanation
Red	Oil filling
Blue	Fuel
1	Metal diaphragm
2	Plunger

Limp-home Mode

If a fault is diagnosed in the system, such as e.g. failure of the high-pressure sensor, the fuel-supply control valve is de-energized; the fuel then flows via a so-called bypass into the rail.

In the event of HPI limp-home mode, turbocharging is deactivated by an opening of the wastegate valves.

Causes of HPI limp-home mode can be:

- Implausible high-pressure sensor values
- Failure of the fuel-supply control valve
- Leakage in the high-pressure system
- Failure of the high-pressure pump
- Failure of the high-pressure sensor

N54 HPI injection schematic

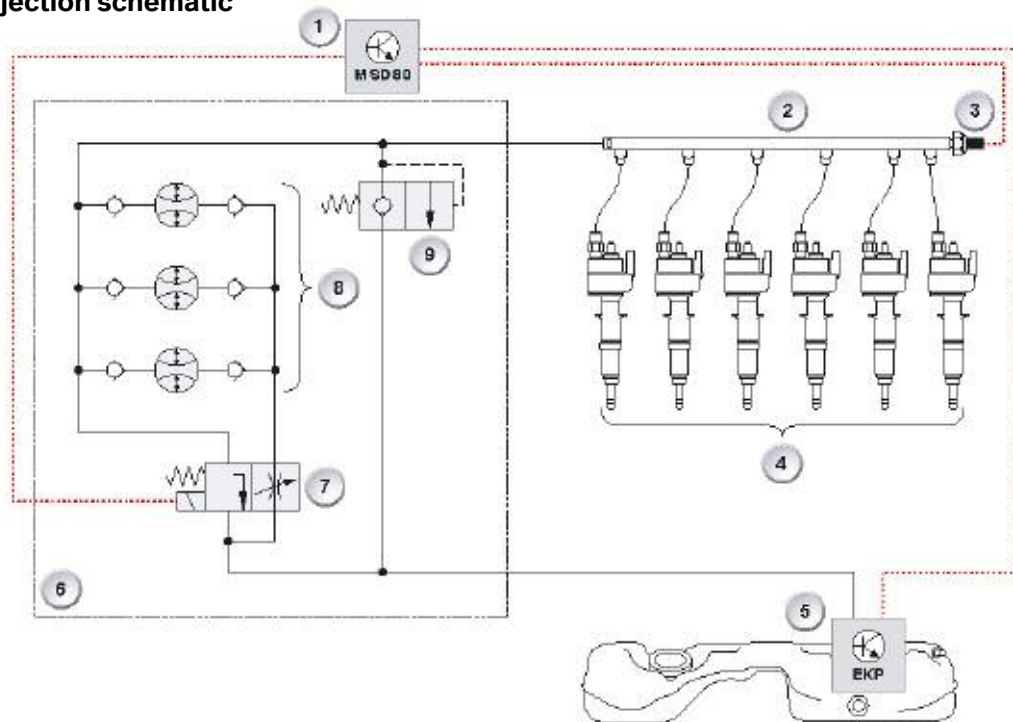

Index	Explanation	Index	Explanation
1	Engine control module (MSD80)	6	High-pressure pump
2	Fuel rail	7	Fuel supply control valve
3	High pressure sensor	8	High pressure pump with non-return valves
4	Piezo injectors	9	Pressure limiting valve with bypass
5	Electric fuel pump		

■ Fuel System Safety

Working on this fuel system is only permitted after the engine has cooled down. The coolant temperature must not exceed 40 °C. This must be observed without fail because otherwise there is a danger of fuel sprayback on account of the residual pressure in the high-pressure system.

When working on the high-pressure fuel system, take particular care to ensure conditions of absolute cleanliness and follow the work sequences described in the repair instructions. Even the tiniest contaminants and damage to the screw connections on the high-pressure lines can cause leaks.

ACHTUNG!	Öffnen des Kraftstoffsystems bei Kühlmitteltemperatur über 40 °C nicht zulässig. Gefahr von Körperverletzung. Reparaturanleitung beachten.
CAUTION!	Do not open the fuel system if the coolant temperature is above 40 °C/104 °F – risk of injury! Consult the repair manual.
ATTENTION !	Il est interdit d'ouvrir le système d'alimentation en carburant lorsque la température du liquide de refroidissement est supérieure à 40 °C. Risque de blessure. Respecter les instructions du Manuel de réparation.
¡ATENCIÓN!	Prohibido abrir el sistema de combustible cuando la temperatura del líquido refrigerante supera los 40 °C. Peligro de lesiones. Consultar el manual de reparaciones.
注意!	冷却液温度高于40摄氏度时禁止打开燃油系统。存在身体伤害的危险。注意维修说明。

7587417

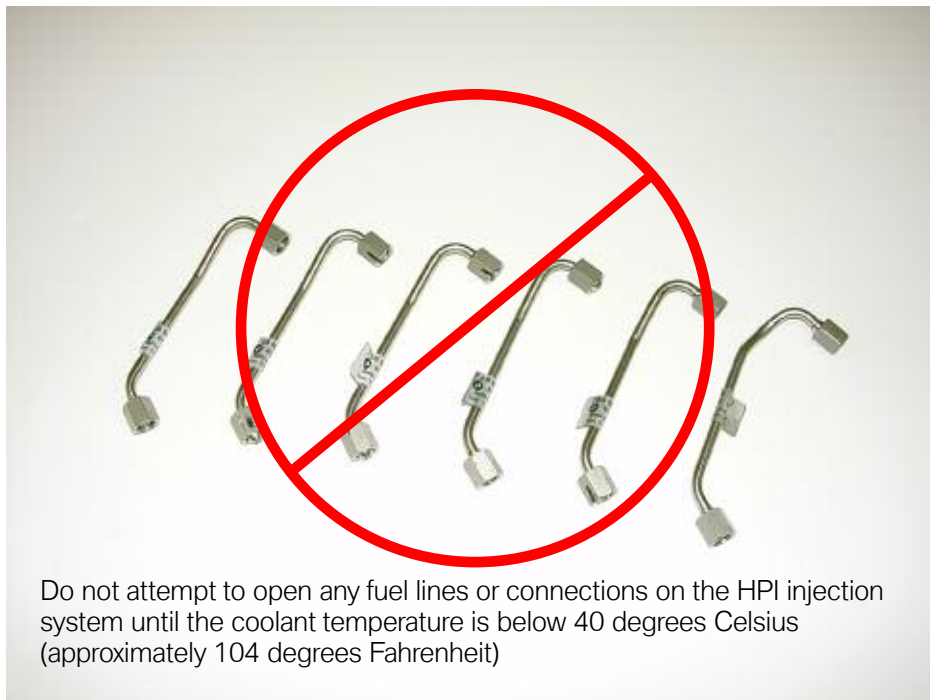

Piezo Fuel Injectors

The outward-opening piezo-injector makes it possible to spray direct injection on to the top of the cylinder. This component ensures that the injected fuel spray cone remains stable, even under the prevailing influences of pressure and temperature in the combustion chamber.

The extremely quick opening of the nozzle needle of the piezo-injector permits injection pressures of up to 200 bar. Thus it is possible to inject fuel into the combustion chamber under the extreme conditions of the power cycles limited by the valve opening times.



The piezo-injector is located in the center of the cylinder head, next to the spark plug, between the intake and exhaust valves. This installation position prevents the cylinder walls or the piston crown from being wet with injected fuel. A uniform formation of the homogeneous air/fuel mixture is obtained with the aid of the gas movement in the combustion chamber and a stable fuel spray cone.

The gas movement is influenced on the one hand by the geometry of the intake passages and on the other hand by the shape of the piston crown. The injected fuel is swirled in the combustion chamber with the boost air until a homogeneous mixture is available throughout the compression space at the point of ignition.

Note: When working on the fuel system, it is important to ensure that the ignition coils are not saturated with fuel. The resistance of the silicone material is significantly reduced when wet with fuel. This can cause arcing at the spark-plug and lead to misfires.

- Before making modifications to the fuel system, remove the ignition coils and protect the spark-plug holes against spilled fuel with a shop rag.
- Before refitting the piezo-injector, remove the ignition coils and ensure absolute cleanliness.
- Ignition coils that have been heavily saturated with fuel must be replaced.



HPI uses piezo injectors and HDE uses solenoid type injectors. See N55 training material.

■ Injector Design and Function

The piezo-injector essentially consists of three sub-assemblies. The expansion of the energized piezo-element lifts the nozzle needle outwards from its valve seat. To be able to counter the different operating temperatures with comparable valve lifts, the injector has a thermal compensating element.

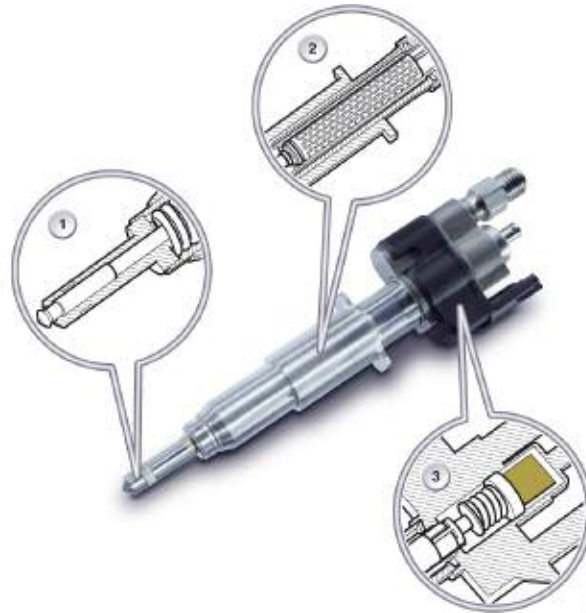

Index	Explanation	Index	Explanation
1	Outward opening nozzle needle	3	Thermal compensator
2	Piezo-element		

The nozzle needle is pressed outwards from its tapered valve seat. This opens up an annular orifice. The pressurized fuel flows through this annular orifice and forms a hollow cone, the spray angle of which is not dependent on the backpressure in the combustion chamber.



Do not attempt to clean the injectors in any way. This may result in damage which can effect the spray pattern.

Any divergence in the spray pattern can cause damage to the spark plug or the engine itself.

Outward opening injector nozzle needle

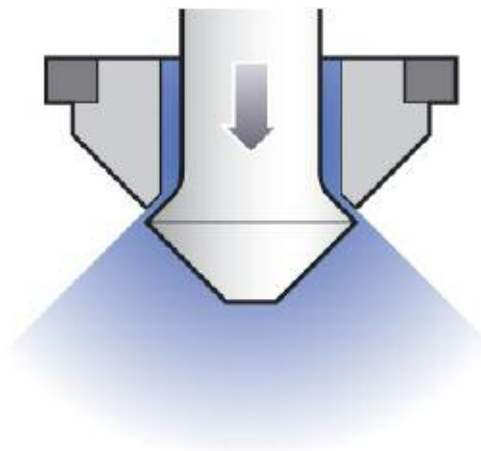

The spray cone (1) of a piezo-injector can diverge during operation (2). Due to the formation of soot inside the engine, such divergence is perfectly normal and acceptable to a certain extent. If, however, spray divergence reaches the stage where it begins to spray the spark plug wet, the spark plug may incur damage.

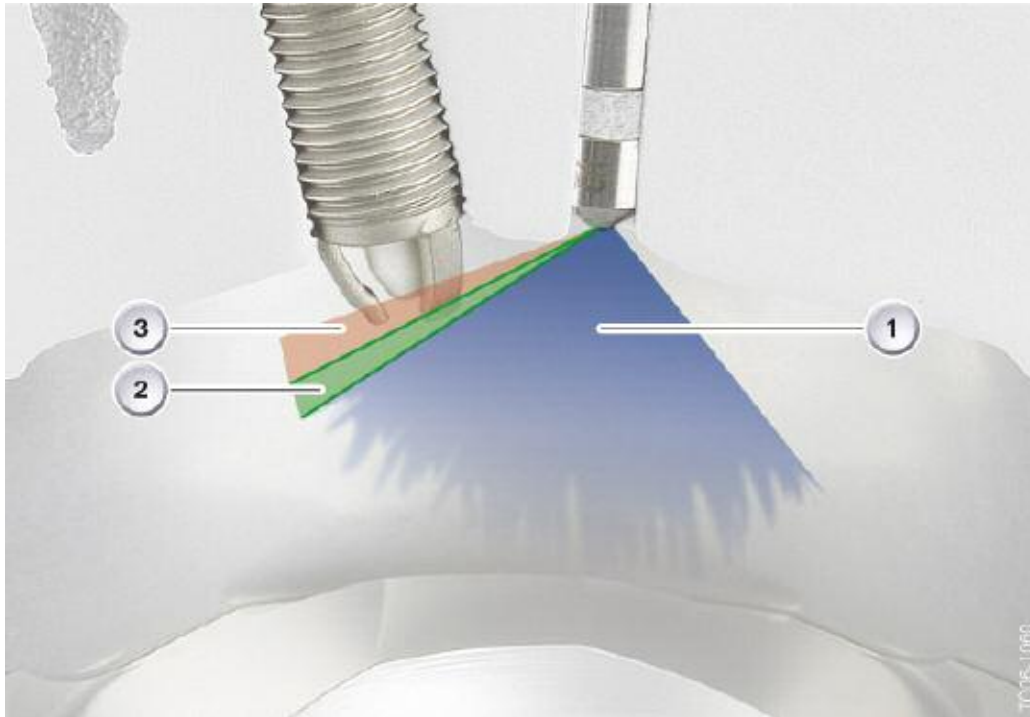

Index	Explanation	Index	Explanation
1	Ideal "spray" cone	3	Non-permitted divergence of spray cone
2	Permitted divergence of spray cone		



Replace the Teflon sealing ring when fitting and removing the piezo-injector. This also applies when an injector that has just been fitted has to be removed again after an engine start.

A piezo-injector provided with a new Teflon sealing ring should be fitted as quickly as possible because the Teflon sealing ring could swell up. Please observe the repair instructions and follow without fail.

When fitting, make sure that the piezo injector is correctly seated. The hold-down element for securing the piezo-injectors must rest on both injector tabs, otherwise the necessary force is not applied to the piezo-injector. Do not clean the nozzle-needle tip of the piezo-injector.

■ Injection Strategy

Injection of the fuel mass required for the operating situation can take place in up to three individual injections. Which option is used in the relevant operating situation is dependent on engine load and speed. Here, the actual time resulting from the engine speed available for metering the fuel is an important framework quantity.

A special situation during the operation of any engine is the range in which a high load occurs at low engine speed, so-called "Low End Torque" operation. In this operating situation, the required fuel mass is metered to the engine in three individual injections.

This results in a highly effective mixture formation which in the final analysis has the effect of both increasing power output and saving fuel.

In order to bring the catalytic converters up to operating temperature as quickly as possible, the system has a catalyst-heating mode for when the engine is started from cold. In this mode, combustion heat is intentionally introduced into the exhaust train and not used first and foremost to develop power output.

The point of ignition is moved to 30° (crankshaft degrees) after TDC. The main quantity of the required fuel is injected before TDC and mixed with the boost air. The piston is situated after TDC in its downward travel such that the air/fuel mixture is already expanding again, which reduces the ignitability of the mixture at the spark plug.

In order to ignite the mixture reliably, a small residual quantity of fuel is injected 25° after TDC and this guarantees an ignitable mixture at the spark plug. This small fuel quantity therefore provides for ignition of the residual charge in the combustion chamber.

This operating mode is set by the engine-management system after a maximum period of 60 seconds from engine starting but is terminated if the catalytic-converter response temperature is reached earlier.

N54 injection strategy

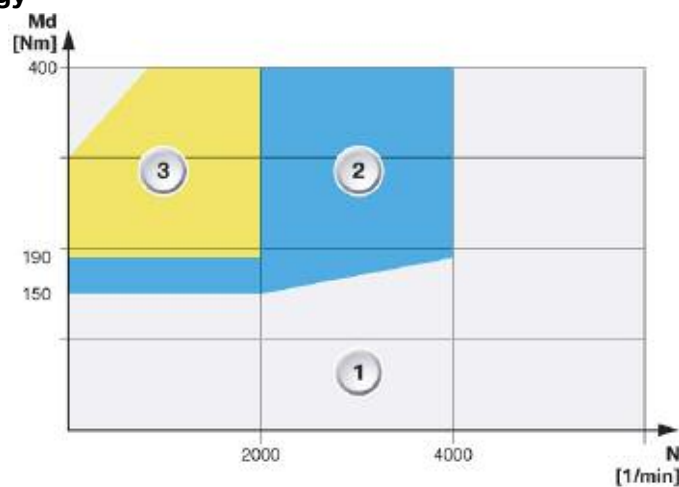

Index	Explanation	Index	Explanation
1	Single injection event	3	Triple injection event
2	Double injection event		

Piezo Element

The movement of the nozzle needle in the injector is generated by a piezo-element.

A piezo-element is an electromechanical converter, i.e. it consists of a ceramic material which converts electrical energy directly into mechanical energy (force/travel). A familiar application is the piezo cigarette lighter - when a piezo-crystal is pressed, voltage is generated until a spark flashes and ignites the gas.

In the case of the piezo-actuator, voltage is generated so that the crystal expands. In order to achieve greater travel, it is possible to design a piezo-element in several layers.

The actuator module consists of layers of the piezo-ceramic material connected mechanically in series and electrically in parallel. The deflection of a piezo-crystal is dependent on the applied voltage up to a maximum deflection; the higher the voltage, the greater the travel.

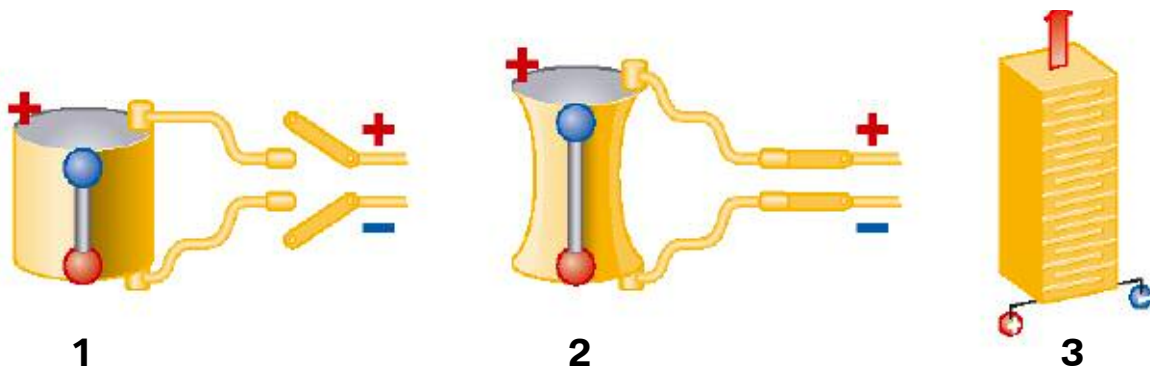

Index	Explanation	Index	Explanation
1	Piezo crystal - not energized	3	Piezo element in layers (stacked)
2	Piezo crystal - energized		

■ Injector Adjustment

When the injectors are manufactured, a multitude of measurement data is recorded at specific points in the factory. In this way, the tolerance ranges for injector-quantity adjustment are determined and specified in a six-digit number combination.

Information on the lift performance of the injector is also added for injector voltage adjustment. Injector adjustment is required because of the individual voltage demand of each piezo actuator. An allocation is made to a voltage demand category, which is included in the number combination on the injector.

These data items are transmitted to the ECM. During engine operation, these values are used to compensate for deviations in the metering and switching performance.



When replacing an injector, it is absolutely essentially to carry out an injector adjustment.

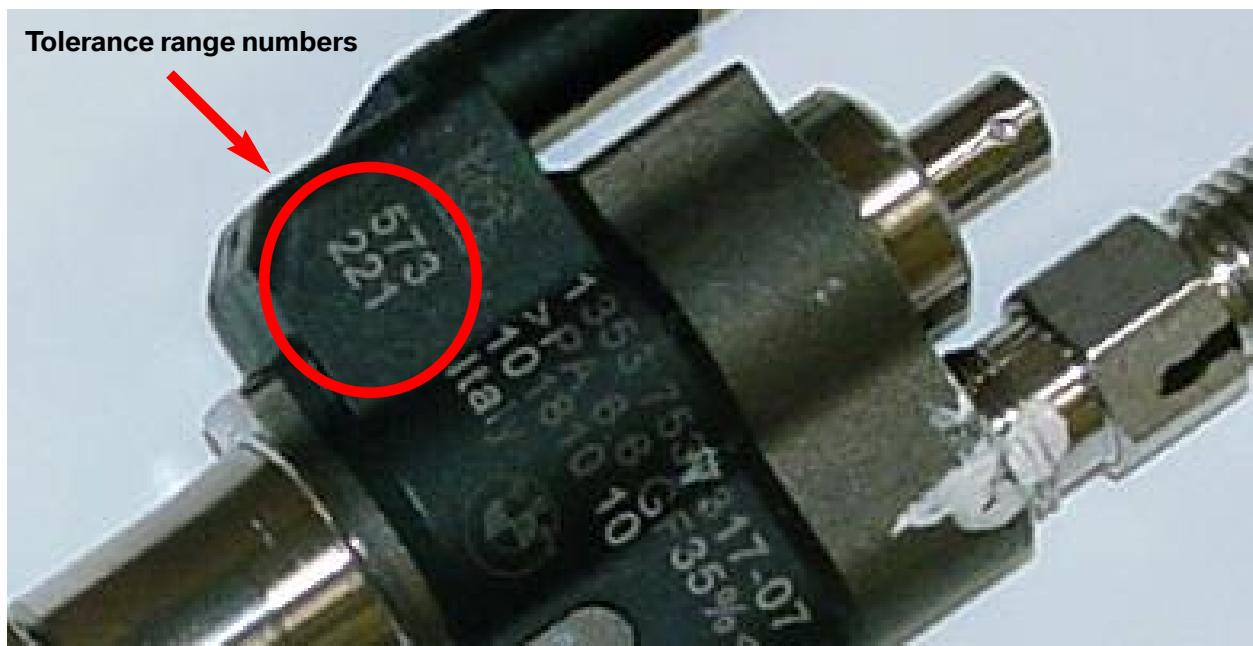

■ Injector Control and Adaptation

The fuel mass required for the operating situation is injected by the piezo-injector into the combustion chamber. This mass can be influenced by three correcting variables:

- the rail pressure
- the injector opening time
- the injector opening lift

The injector opening time and the injector opening lift are activated directly at the piezo injector. The opening time is controlled via the ti signal and the opening lift via the energy quantity in the activation of the piezo-injector.

■ Injector Adaptation

The fuel masses and injection cycles determined from the load/speed map are included in a pilot-control program map. Here, while further framework parameters are taken into consideration, the energy quantities and injector opening times required to activate the injectors are determined.

The N54 engine can be safely and reliably operated with these program-map values.

■ Optimization

For optimization of:

- Emission values
- Smooth running
- Fuel consumption
- Power output

the controlled variables of energy quantities and injector opening times are continuously monitored. This occurs on a bank-selective basis by way of lambda closed-loop control.

The residual oxygen in the exhaust gas is measured in each case for cylinder bank 1 and cylinder bank 2. This measurement result is compared with the values expected from the set correcting variables. The result of a deviation is that the injector opening signal is adapted. This adaptation is stored in the control unit and is therefore available for subsequent engine operation. However, these stored values are lost when the system is flashed and must be relearned. A further adaptation of the injector activation takes place depending on time and use. This cylinder-selective adaptation involves a check of the residual-oxygen content with a conclusion as to the cylinder causing the situation. To this end, it is necessary for part of the exhaust-gas flow not to be swirled in the turbocharger. For this reason, the flap of the wastegate valve must be fully opened, i.e. swung out of the exhaust-gas flow. This wastegate-flap position extends beyond its normal opening position in engine operation. Based on the result of this cylinder-selective monitoring, the energy quantity is adapted if necessary to activate the injectors.

Furthermore, the cylinder-selective adaptation includes if necessary an adaptation of the injector opening signal based on smooth running monitoring of the N54 engine. Overall adaptation of the injectors is limited to a 15% additional quantity.

HDE Fuel Injection

The high pressure fuel injection system (HDE) is used on the N55 engine. In contrast to high precision injection (HPI), HDE uses solenoid fuel injectors with multi-hole nozzles.

The following overview shows the complete fuel injection system. The system is similar to the N54 fuel injection. Although the same high pressure pump, pressure sensor, and fuel rail are used, the high pressure fuel injection valves are new. The HDE system uses Bosch high pressure solenoid type fuel injection valves with the designation HDEV5.2.

N55, overview of high pressure fuel injection system

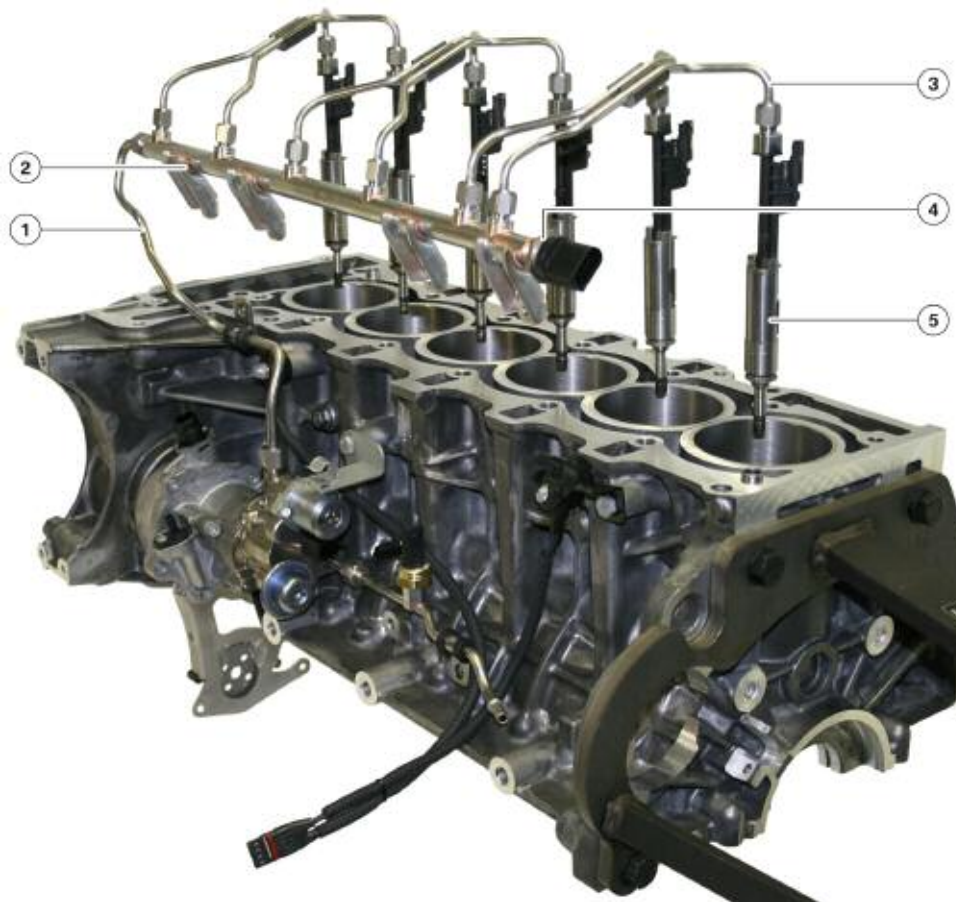

Index	Explanation
1	High pressure line
2	Rail
3	High pressure line
4	Fuel rail pressure sensor
5	Solenoid valve fuel injector

VALVETRONIC III

The main differences between VALVETRONIC III and VALVETRONIC II are in the arrangement of the VALVETRONIC servomotor and the VALVETRONIC sensor. As in VALVETRONIC II, the turbulence level is increased at the end of the compression cycle for the purpose of optimizing the mixture formation with the use of phasing and masking measures. This movement of the cylinder charge improves the combustion during partial load operation and in catalytic converter heating mode. The quench areas also contribute to mixture formation.

Phasing

Phasing results in a lift difference between both intake valves of up to 1.8 mm in the lower partial load range. Consequently, the flow of fresh air is distributed asymmetrically.

Masking

Masking refers to the design of the valve seats. This machining ensures that the incoming fresh air is aligned in such a way as to give rise to the required cylinder charge movement. The advantage of this measure is that the combustion retardation is reduced by approximately 10° of crankshaft rotation. The combustion process takes place faster and a larger valve overlap can be achieved, thus considerably reducing NOx emissions.

N55, Top of the combustion chamber

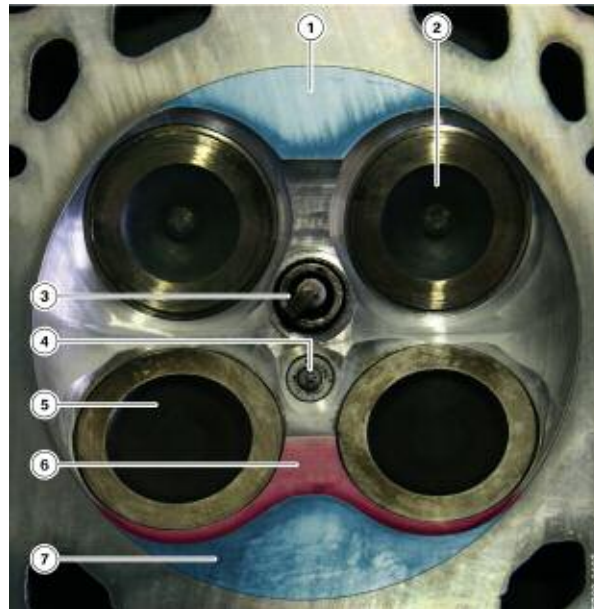

Index	Explanation	Index	Explanation
1	Quench area	5	Intake valve
2	Exhaust valves	6	Masking
3	Spark plug	7	Quench area
4	Fuel injector		

Combustion Chamber Geometry

The following graphic shows the arrangement of the individual components in the combustion chamber. It can be seen that the BMW (spray-guided) high precision injection (HPI) system is not used but rather a Bosch solenoid valve fuel injector with multi-hole nozzle. The fuel injection is specially adapted to the combination of VALVETRONIC III and turbocharging. For better illustration, a set of valves has been removed in the graphic.

N55, combustion chamber with components

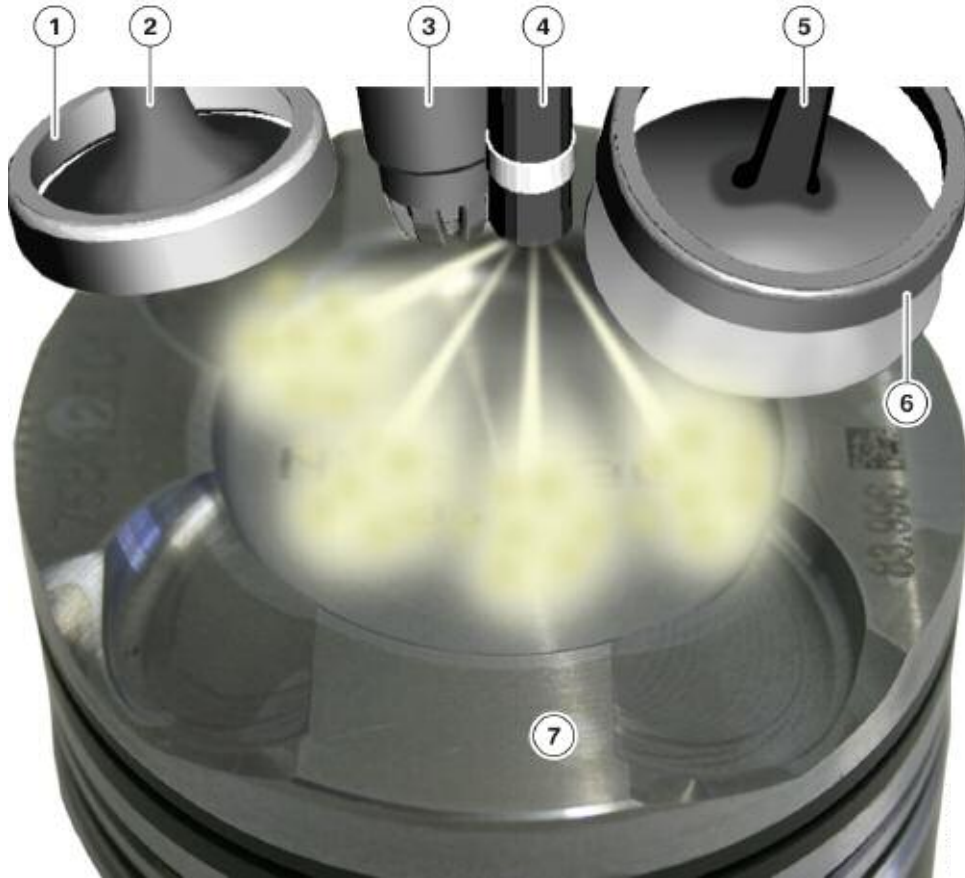

Index	Explanation
1	Valve seat, exhaust valve
2	Exhaust valve
3	Spark plug
4	Fuel injector
5	Intake valve
6	Valve seat, intake valve
7	Piston

The VALVETRONIC III servomotor contains a sensor for determining the position of the motor and the eccentric shaft. The servomotor is lubricated with engine oil by means of an oil spray nozzle (1) aimed directly at the worm drive and the eccentric shaft mechanism.

N55, design of valve lift adjustment

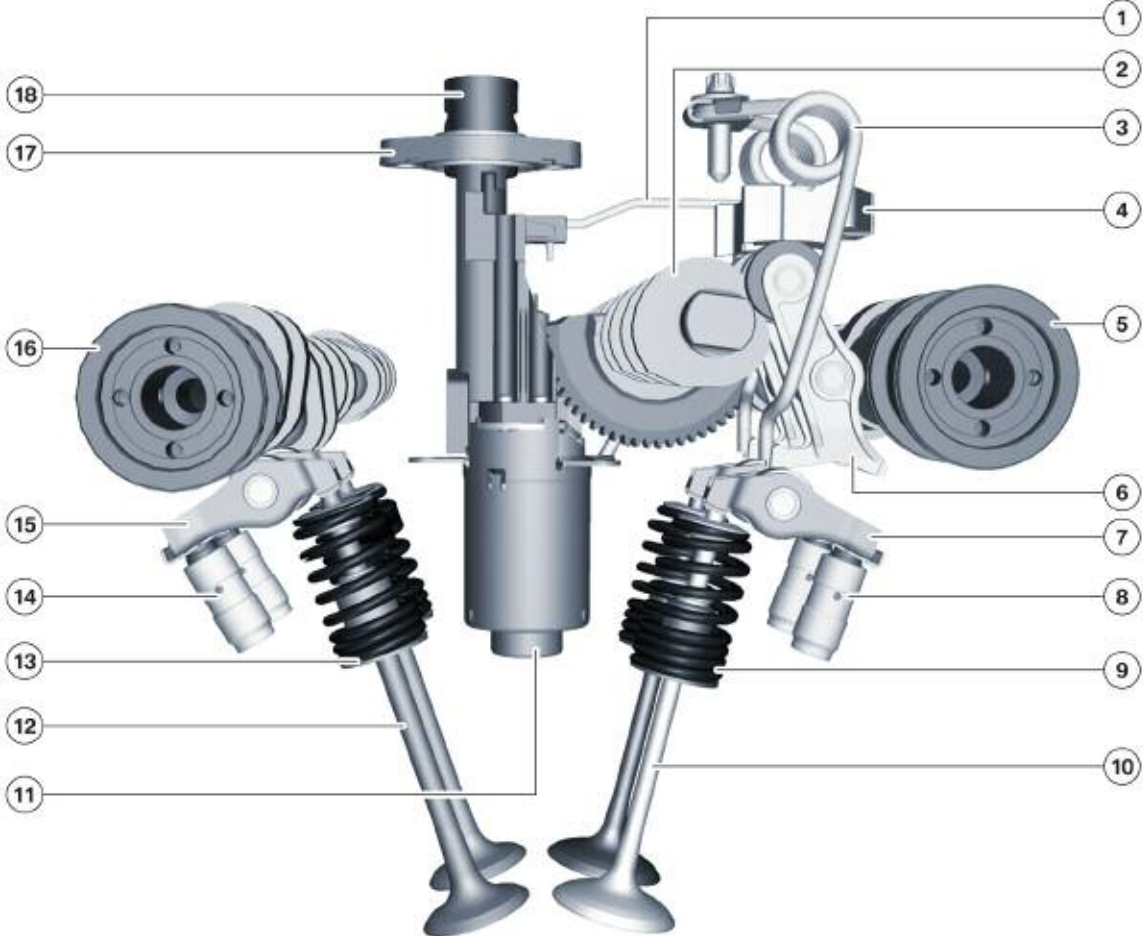

Index	Explanation	Index	Explanation
1	Oil spray nozzle	10	Intake valve
2	Eccentric shaft	11	VALVETRONIC servomotor
3	Return spring	12	Exhaust valve
4	Gate block	13	Valve spring
5	Inlet camshaft	14	Hydraulic valve lash adjustment
6	Intermediate lever	15	Roller cam follower, exhaust
7	Roller cam follower, intake	16	Exhaust camshaft
8	Hydraulic valve lash adjustment	17	Sealing sleeve
9	Valve spring	18	Socket

VALVETRONIC Servomotor

A brushless direct current motor (BLDC motor) is used. The BLCD motor is maintenance-free and very powerful, due to the contactless energy transfer system. The use of integrated electronic modules ensures precision control.

The VALVETRONIC servomotor has the following special features:

- Open concept (engine oil is directly supplied to the motor).
- The eccentric shaft angle is determined by angle increments from the integrated sensor system.
- Power consumption is reduced by about 50%.
- Higher actuating dynamics (e.g. cylinder-selective adjustment, idle speed control, etc.).
- Lightweight design is approximately 600 grams.

Function

Actuation of the VALVETRONIC servomotor is limited to a maximum of 40 amps. A maximum of 20 amps are available over a period of > 200 milliseconds. The VALVETRONIC servomotor is actuated by a pulse width modulated signal. The duty cycle is between 5% and 98%.

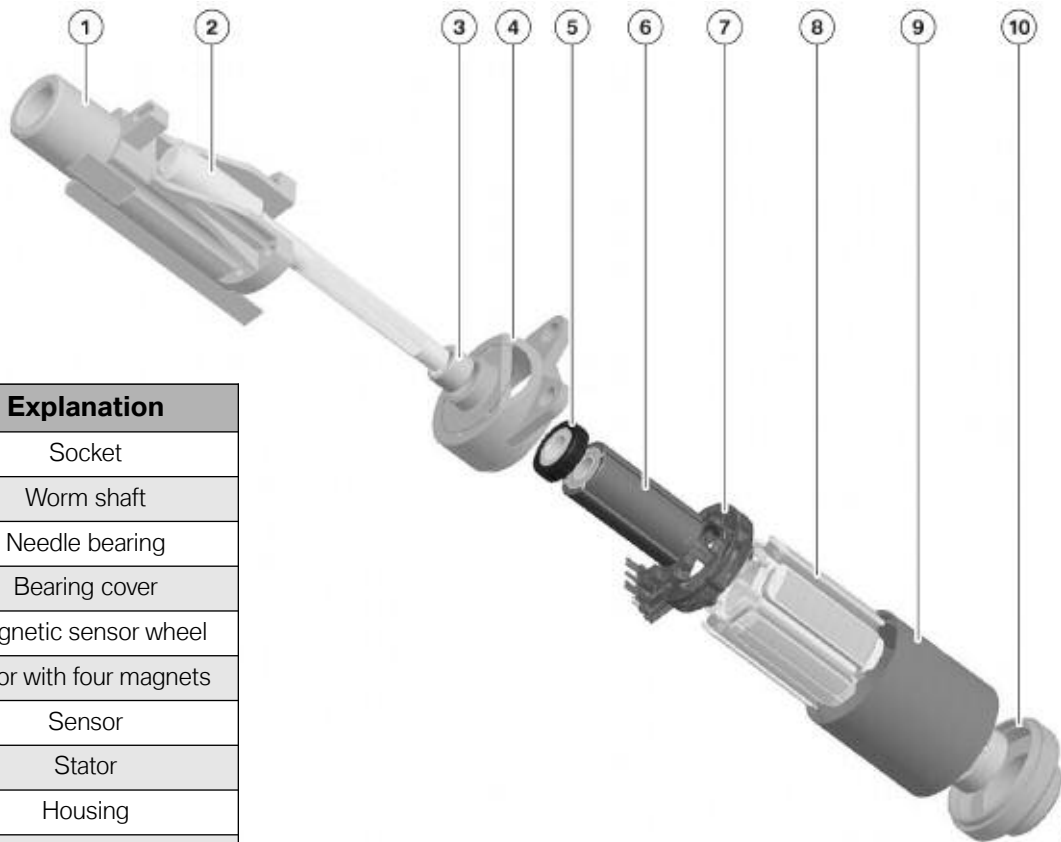

Index	Explanation
1	Socket
2	Worm shaft
3	Needle bearing
4	Bearing cover
5	Magnetic sensor wheel
6	Rotor with four magnets
7	Sensor
8	Stator
9	Housing
10	Bearing